

Structural relation between the vacuum space and the electron

Paramahansa Tewari^{a)}

Vinodini Nivas, P.O. Gotegali, Karwar 581317, Karnataka, India

(Received 13 March 2017; accepted 10 February 2018; published online 13 March 2018)

Abstract: This paper presents a formulation of Absolute Principles for vacuum-space that enable revealing the process of creation of a stable electron and its known properties of mass and charge. Fundamental equations on the electron's charge and mass are derived from first principles from the vacuum vortex of the electron's structure. Also, generation of electrostatic, electromagnetic, and gravitational fields are shown to arise from the vacuum-vortex structure of the electron. The electron and positron have been pinpointed to be the fundamental particles of matter. Coulomb's equation for electrical attraction, dielectric and permeability constants for vacuum, gravitational constant, angular momentum, and magnetic moment for the electron are derived from the charge and mass equations of the electron. It is shown that the mass and charge equations of the electron are applicable for all stable particles, atoms, and even cosmic bodies such as the planets, sun, and galaxies. Kepler's laws are derived from the vacuum space vortex causing axial rotation of the Sun and orbital rotation of the planets. The Earth and the planets with axial rotation are shown to be enclosed by their respective vacuum space vortices that cause gravity field on their surfaces, axial rotation, and generating surface charge. Their masses too can be derived from the tangential vacuum velocity field on their surfaces. The vacuum space vortices, spreading far beyond Pluto in the solar planetary plane, and also those enclosing the galaxy core and rotating the stars, are mistaken as dark matter, presently. The spin of the galaxy core is calculated to be at the velocity of light, causing creation of matter continuously, starting with electrons/positrons and assembling into hydrogen and other atoms. By creation of the electron and its fields and properties from the vacuum space vortex, it is proved that the primary source of cosmic energy in the universe is the dynamic state of the vacuum space vortices. The universe, originally, is a sphere of vacuum space, before creation of matter and fields, existing within an infinite void of nothingness. The radius of the vacuum space sphere has to be a minimum of 3.3×10^{31} cm so as to retain the created matter within the universal boundary of the vacuum and nothingness (void). The universe has only two constants: velocity of light relative to the vacuum space c and electron radius r_e . The ratio c / r_e is the limiting velocity gradient in vacuum vortex circulation, at which the vacuum's flow breaks down into stable electrons and positrons. © 2018 Physics Essays Publication.

[<http://dx.doi.org/10.4006/0836-1398-31.1.108>]

Résumé: Cet article présente la formulation de Principes Absolus pour le vide spatial qui permettent de révéler le processus de création d'un électron stable et ses propriétés connues de masse et de charge. Les équations fondamentales pour la charge et la masse de l'électron sont dérivées des premiers principes du vortex dans le vide de la structure de l'électron. De plus, la génération de champs électrostatiques, électromagnétiques et gravitationnels est montrée de provenir de la structure du vortex sous vide de l'électron. L'électron et le positron ont été identifiés comme étant les particules fondamentales de la matière. L'équation de Coulomb pour l'attraction électrique, les constantes diélectriques et de perméabilité du vide, la constante gravitationnelle, le moment angulaire et le moment magnétique pour l'électron sont dérivées des équations de charge et de masse de l'électron. Il est montré que les équations de masse et de charge de l'électron peuvent être appliquées à toutes les particules stables, les atomes et même les corps cosmiques comme les planètes, le soleil et les galaxies. Les lois de Kepler sont dérivées du vortex du vide spatial entraînant une rotation axiale du soleil et une rotation orbitale des planètes. La Terre et les planètes à rotation axiale sont montrées comme étant entourées par leurs respectifs vortex du vide spatial qui provoquent un champ de gravité sur leurs surfaces, une rotation axiale et la génération de charge de surface. Leurs masses aussi peuvent être dérivées du champ de vitesse tangentielle dans le vide sur leurs surfaces. Les vortex du vide spatial, qui s'étendent bien au-delà de Pluton dans le plan planétaire solaire, et aussi ceux qui entourent le noyau de la galaxie et tournent autour des étoiles, sont présentement confondus avec la matière noire. Le spin du noyau de la galaxie est

^{a)}Deceased. Address all correspondence to: a_tewari@icloud.com.

calculé d'avoir la vitesse de la lumière, provoquant la création continue de matière, en commençant par les électrons/positrons et en les combinant en hydrogène et autres atomes. Par la création de l'électron et de ses champs et propriétés à partir du vortex du vide spatial, il est prouvé que la source primaire de l'énergie cosmique dans l'univers est l'état dynamique des vortex du vide spatial. L'univers, à l'origine, est une sphère de vide spatial, avant la création de matière et des champs, existant dans un vide infini de néant. Le rayon de la sphère du vide spatial doit être au moins $3,3 \times 10^{31}$ cm de façon à retenir la matière créée dans la limite universelle du vide et du néant (vide). L'univers n'a que deux constantes: la vitesse de la lumière c par rapport à l'espace vide et le rayon électronique r_e . Le rapport c/r_e est le gradient de vitesse limite dans la circulation du vortex dans le vide, auquel le flux dans le vide se décompose en électrons stables et positrons.

Key words: Vacuum Space; Void; Electron Creation; Continuous Creation; Velocity Fields; Acceleration Fields; Gravitational Field; Planck Constant, Shell of Light.

I. INTRODUCTION

It was Rene Descartes, the French mathematician and philosopher, who, perhaps for the first time in a scientific sense, assigned a reality to the medium of space as a fluid-entity, already known at that time as ether. According to Descartes, large cosmic ether vortices existed throughout the universe. One such vortex carried the planets around the sun, and countless smaller vortices aggregated into different sizes of universal matter, filling the whole of space. He explained gravity by the pressure and impact of ether on bodies; and, framed principles of inertial tendencies of matter for straight line motion, based on the property of the fluidity of the space-substratum filled with ether vortices. The transmission of the then known magnetic forces and the force of gravity between the earth and the planetary bodies found explanations in Cartesian philosophy with physical contacts between the interacting entities mediated by the intervening ether. The theory of Descartes at that time was the most convincing natural philosophy, and was based on a single *dynamic ether*. The theory remained in acceptance for almost a century after publication of Newton's *Principia*.

Newton's laws of motion took into account the principle of inertia for straight line motion as conceived by Descartes,¹ and Galileo's experimental discoveries on freely falling bodies and their motion on inclined planes; but, ether was not invoked to explain the properties of mass, inertia (which were introduced in Newton's laws of motion) and the force of gravity. Thus, the medium of space, except for its utility as a continuous fluid-substratum for the transmission of light waves, was again made inert and inactive for transmission of forces; and, this led to the reintroduction of the principle of "action at a distance." Based on this principle, R. G. Bosovich (1711–1787) tried to explain all physical effects and, further, Coulomb and Ampere invoked it in explaining the mutual action of forces between charged bodies and electric currents. In contrast, Faraday's researches led him to the conclusion that electromagnetic induction cannot take place without the intervening medium (field). Faraday introduced the concept of continuously varying electric and magnetic fields, signifying space to be a continuous substratum, and "action at a distance" as not the basic principle. He also suggested that an atom could be a structure of fields of forces—electric, magnetic, and gravitational, existing around its central point. On the existence of ether, it was Faraday's belief

that it may have its utility in other physical effects, in addition to providing a medium for transmission of light. Based on Faraday's concepts, Maxwell wrote equations using hydrodynamics to model ether, postulating it as an incompressible fluid. Helmholtz conceived the ether vortex filament as electric current; and, W. Thomson believed² that "the magnetic energy is the kinetic energy of a medium occupying the whole space, and that electric energy is the energy of strain of the same medium." Atomic structure as a vortex motion was also proposed by Thomson and others, and after the electron's discovery (1897), Lamar concluded that the electron is a structure in the ether and that all matter consisted of electrons only.

Problems arose around 1905, as the concepts of the vortex structure of electrons in an incompressible fluid were being researched. One problem was the dissipation of vortex motion, since the streamlines in a vortex may tend to dilate outward (W. Thomson). Another problem pertained to the difficulty of the transmission of an electromagnetic field in this fluid, at the enormous speed of light, for which, if ether properties are considered akin to matter with very low density, the elasticity should be near to that of steel. While these difficulties were yet to be overcome, Einstein's Theory of Relativity (1905), proposed around that time, postulated the medium of space as empty extension, meaning that no point of space was to be assigned with a velocity-vector (or "velocity field"), thus making the very existence of ether superfluous.

The space-vortex structure of the electron, based on the writer's works,^{3,4} referred in this paper, provides solutions to both the above problems. The high elasticity required for the fluid-ether is avoided by postulating it as a *nonmaterial* and incompressible fluid devoid of any known property of matter, such as mass, density, discreteness, viscosity, elasticity, or compressibility, etc. Further, if the properties of "mass" and "charge" of an electron are to be derived from first principles, then a mass-less and charge-less fluid that, as a vortex, can form the structure of an electron, must be postulated. The proof of this postulate—that the universal substratum of space with nonmaterial^{b)} properties has real existence—is provided by deriving the basic properties of

^{b)}"Nonmaterial" signifies a mass-less, density-less, incompressible, non-viscous and continuous fluid.

the electron (mass, charge, gravity, etc.) from the vacuum space^{c)} vortex structure of the electron, and by explaining its behavior in physical as well as quantitative terms, as experimentally observed. The other problem of the outward dissipation of the vortex motion is solved by introducing a *discontinuity* in the energy-distribution at the vortex center, as shown later.

This paper is in Two Parts:

PART—I

Subatomic and atomic—A dimensional analysis to reduce the number of basic units used to describe physical reality from four to three, thereby relating electromagnetic (EM) quantities to mechanical quantities in a dimensionally correct manner.

PART—II

A dimensional analysis of Solar space vortex

PART—I: Subatomic and atomic

II. POSTULATES

1. The medium of vacuum space, throughout the universe, is an eternally existing, nonmaterial, incompressible, continuous, isotropic fluid substratum.
2. The medium of vacuum space has a limiting flow velocity equal to the speed of light relative to the absolute vacuum.
3. The medium of universal vacuum space is eternal and inherent with motion.

A. Breakdown of fluid void space

The creation of an electron requires a breakdown of the flow of the fluid medium of vacuum space (also referred to as space). Figure 1 shows an irrotational circular vortex of vacuum space with concentric streamlines. Consider an element of the vacuum space of volume $dA dr$, as shown, on which a tangential velocity field u is acting. If this vortex pertains to a viscous fluid of density ρ , the mass of the element will be: $dm = \rho dA dr$. There will be a pressure differential on the two surfaces of the element as shown. The two equal and opposite forces acting on the element will be: (a) an inwardly directed, radial, net pressure force and (b) a centrifugal force, giving the relation: Force = net pressure force = centrifugal force = $dp dA = dm \times u^2/r = (\rho dA dr) u^2/r$, from which

$$\frac{\text{Force}}{dm} = \frac{(dpdA)}{(pdAdr)} = \frac{u^2}{r}. \tag{1}$$

In an irrotational circular plane vortex, it can be shown that the velocity of a space point at distance r from the vortex center is given by

$$ur = \text{constant}. \tag{2}$$

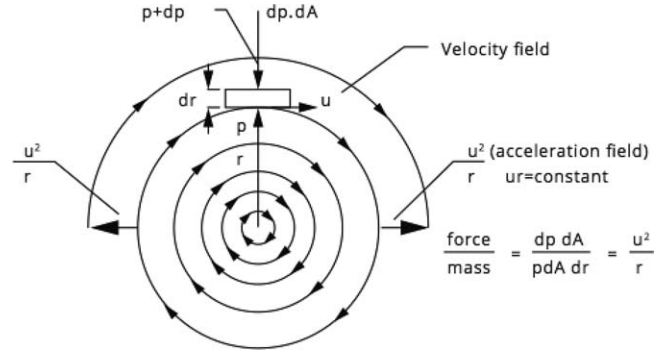

FIG. 1. Irrotational vortex.

When a vortex of *mass-less vacuum* space is considered, there is neither inward force (on the element) due to the pressure-differential, nor outward centrifugal force, because the property of mass is common to the origin of both these forces. On a circular streamline, and at each of its points, the velocity field u creates a radial outward acceleration field u^2/r that, acting simultaneously on all the diametrically opposite points, tends to create a tearing action to split open the continuous vacuum space. If the speed of the space-circulation reaches the limiting speed c , which is the speed of light in the absolute vacuum, and the velocity-field gradient around the center of the vortex becomes the postulated limiting angular rotation, the vacuum space breaks down, creating a spherical void (Fig. 2), which is defined as a field-less, energy-less and vacuum-less volume of nothingness at the vortex center. The radius of the void created follows the relation, as determined by the ratio:

$$\omega = c/r_e. \tag{3}$$

B. Stability of the void

Figure 3 shows a diametrical cross-section of the spherical void by the plane Y-Z. The circle C rotating around the Y-axis traces a sphere. All points of C have the same angular velocity. The point P_z , at the intersection of C and the Z-axis, will have a tangential velocity c (down the paper), the velocity at which the flow of the fluid-vacuum space breaks down. The radius r_e of C, from Eq. (3), is determined by the ratio c/ω . Consider a point P at the circle C that has the Y-coordinate, $r_e \sin \theta$: it will have a tangential velocity $\omega r_e \sin \theta$ (down the paper at P) because P too has the same angular velocity similar to P_z . The velocity gradient at P_z is c/r_e , which is also the velocity gradient at P, that is, $\omega r_e \sin \theta / r_e \sin \theta$, or ω . Similarly, a point say p_1 in the third quadrant can be shown to have angular velocity ω , similar to point P.

Thus, though the tangential velocity of the vacuum space varies from zero at P_y (located at the axis, Fig. 3) to the maximum value c at P_z in the diametrical plane, the velocity gradient for all the in-between points remains constant at ω (Postulate 2). Similarly, a point, say p_1 in the third quadrant can be shown to have angular velocity ω , similar to the point P. Under these considerations, the geometry of the void

^{c)}The absolute vacuum with nonmaterial properties without matter and fields is termed as "vacuum space" or "vacuum," or "space."

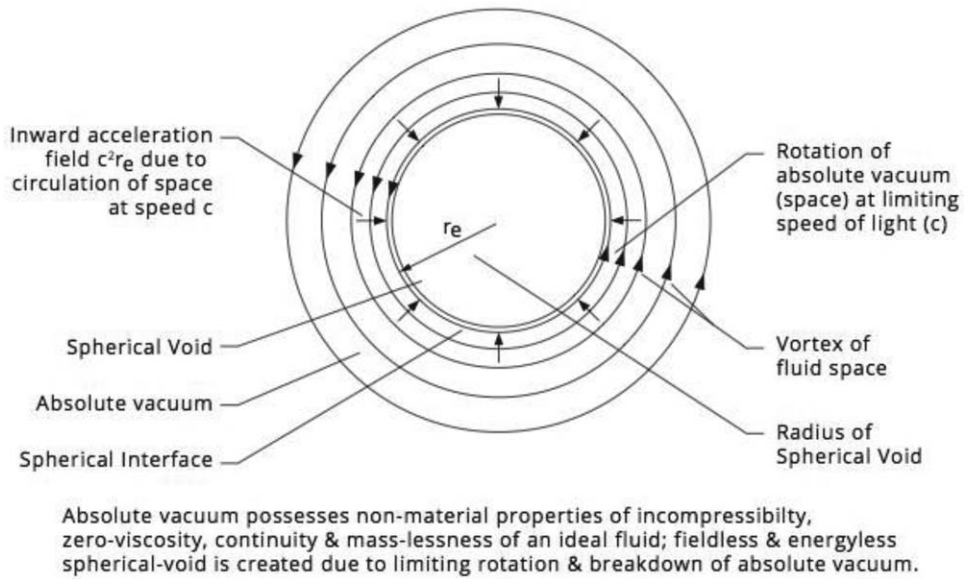
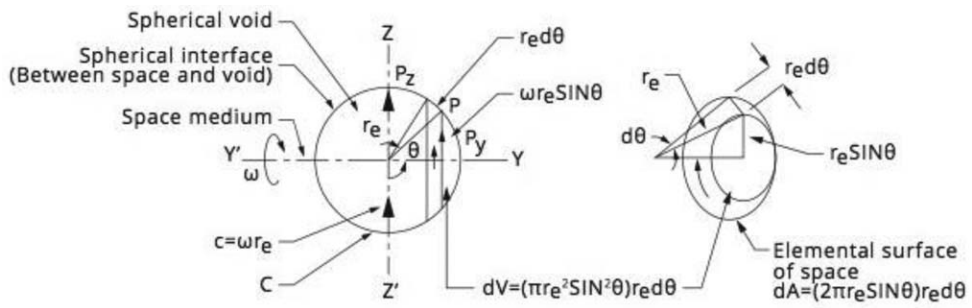
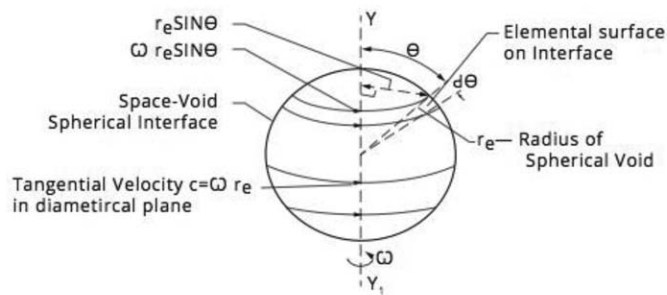

FIG. 2. Vacuum vortex in electron structure.



ω = Angular velocity of spherical interface around y-y
 Void = Fieldless spherical hole in space
 Void-radius $r_e \approx 4 \times 10^{-11}$ Cm

(a)



Universal Constant Ω : Angular Velocity of Interface around Y-Y₁
 Equal to c/r_e
 c : Speed of light in absolute vacuum
 Space : Non-viscous, mobile, continuous, incompressible
 Void : Fieldless, spherical hole in space
 Radius of spherical void $r_e \approx 4 \times 10^{-11}$ cm

(b)

FIG. 3. (a) Velocity field on interface—diametrical cross-section. (b) Velocity field on interface.

created at the vortex center due to the breakdown of the flow of vacuum space is concluded to be *spherical*.

It is shown below that the void is dynamically stable. The creation of the void reverses the direction of the outward acceleration field^{d)} [Eq. (1)] that created the void; because the void (enclosed within the sphere, here referred as the interface) is an empty volume without any “circulating vacuum space” or “energy,” it is at zero potential relative to space surrounding it. Therefore, the acceleration field in Fig. 2 is shown inward. As described above, ω is the limiting velocity gradient c/r_e at the point P_z just prior to the creation of the void. At each point of the interface circle cut by a diametrical plane at right angles to the Y-Z plane (Fig. 3), the tangential velocity c produces maximum radial and inward acceleration, c^2/r_e .

The acceleration field at P is $(\omega r_e \sin \theta)^2/r_e \sin \theta$ along $r_e \sin \theta$. Although the interface is constituted of spinning fluid-space, due to the constancy of $\dot{\varphi}$ on each of its points, it rotates like a surface of a rigid spherical shell of negligible wall thickness.

The stability of the void is due to the following two factors. Consider the circular section of the interface with the diametrical plane (Fig. 2). The radial velocity gradient (ω) is c/r_e . If the void shrinks to a smaller radius, r_e decreases, then $\dot{\varphi}$ will increase proportionately so that $\dot{\varphi} r_e = c$ as per Eq. (2), and also since c is constant; the void thus goes back to its original size. In the event the void tends to grow to a larger size, the *inward* acceleration field c^2/r_e opposes any increase in r_e because it decreases the velocity gradient ω to a lower value, which is no longer sufficient to sustain the void. The sphere of the void is thus reduced to its original size. The other factor is the property of the nonviscosity of space, which maintains the vacuum space-vortex eternally, except for its annihilation on meeting a positron—similar vortex with an oppositely oriented velocity field (discussed later). Further, the energy-less-void being a region of zero potential, the inward acceleration field c^2/r_e on the interface prevents dilation of the streamlines, thereby, preventing dissipation of the vacuum space-circulation away from the interface. Thus, the void maintains its dynamic stability—its volume being regulated due to the constancy of ω and, consequently, the constancy of c and r_e , dictated by the absolute^{e)} properties of the vacuum of space.

C. Fundamental particles of matter

It is seen that the most basic property of the universal medium of vacuum space is expressed by a single universal constant ω that is c/r_e that limits its angular rotation and leads to creation of the fundamental stable vortex. While the void of a definite volume is enclosed within the space-vortex, the vortex itself extends throughout the whole universal-space through its velocity field.^{f)} The space-vortex

structure with a fixed volume of dynamically stable void at its center is defined as the fundamental particle of matter. The properties of “electric charge” and “mass” of the fundamental particle, and the “energy fields” associated with its structure are derived in the following pages.

III. GENERATION OF FIELDS

The vacuum space in circulation at speed c within the volume of the spherical void prior to its creation is, qualitatively, the basic state of energy.^{g)} At the instant of the creation of the void, this energy is pushed out from within the void, and distributed in continuous space as gravity and electro-static fields.

The fields, so created, emanating from the interface of the fundamental particle, become integral with the whole of the universal space. On account of the property of the nonviscosity of space, the void enclosed within the dynamically stable interface at the center of the vortex, and the above fields, exist eternally without any loss of strength. The properties of the fundamental particle described above, and the properties derived below, identify it as the electron itself.

A. Unit electric charge

Electric charge is the effect of space-circulation produced on the interface of the fundamental particle of matter. It is derived as follows. Refer to Fig. 3. Consider an elemental surface on the interface, which has an area: $dA = 2 \pi r_e \sin \theta r_e d\theta$. The tangential velocity of vacuum space at each point of the elemental surface is $\omega r_e \sin \theta$. The electric charge on the elemental surface is defined from the first principles as the “surface integral of the tangential velocity of vacuum on each point of the interface”: $dq = 2 \pi r_e \sin \theta r_e d\theta \omega r_e \sin \theta$. Substituting from Eq. (2), $\omega r_e = c$, in the above equation: $dq = 2 \pi c r_e^2 \sin^2 \theta d\theta$. Integrating for the total electric charge q_e , varying θ from 0 to π

$$q_e = 2 \pi c r_e^2 \int_0^\pi \sin^2 \theta d\theta = (\pi/4) 4 \pi r_e^2 c. \quad (4)$$

The surface integral of the tangential vacuum velocity on the interface is defined as the unit of electrical charge of the fundamental particle of matter.

The dimensions of electric charge from Eq. (4) are: $q_e = L^3/T$. In CGSE system of units

$$\text{cm}^3/\text{s} = \text{CGSE} - \text{unit}. \quad (5)$$

Substituting the experimentally determined value of the electric charge of an electron (4.8×10^{-10} CGSE) and the speed of light in absolute vacuum (3×10^{10} cm/s) in Eq. (4), and using the relationship (5), the radius of the interface enclosing the void is calculated as $r_e = 4 \times 10^{-11}$ cm. A comparison with the classical electron radius, which in modern textbooks is shown as 2.82×10^{-13} cm, reveals that r_e should be about 142 times smaller. However, the following quote supports the results obtained from Eq. (4). “There are several lengths that might aspire to be characteristic of the

^{d)}The acceleration of the vacuum space at a point is termed “acceleration field.”

^{e)}Properties of space, being non-material in nature, are defined to be absolute; unaffected by various conditions of temperature and pressure as applicable to material media.

^{f)}The motion of space leads to the generation of “the velocity field.”

^{g)}The quantitative definition of energy is given later.

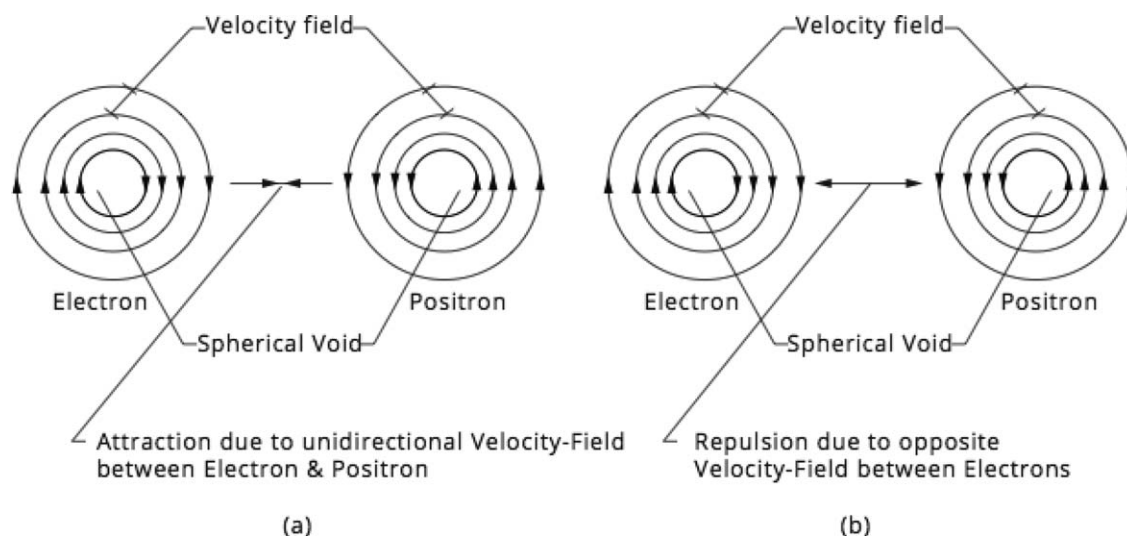

FIG. 4. Attractive and repulsive forces due to velocity fields. The positrons represent 180°—reversed—electrons.

dimensions of the electron. If we proceed from modern theoretical electrodynamics, which has been established better than any other field theory, the conclusion seems to be that the electron has enormous dimensions, not 10^{-13} cm, as expected from classical physics, but 10^{-11} cm (a hundred times greater!).⁴ This value of the electron radius (10^{-11} cm), and its closeness with the radius of the spherical interface enclosing the void derived above from Eq. (4), suggests that the “fundamental particle of matter” described above is the electron—already discovered by the close of the 19th century.

Substituting in Charge Eq. (4), 4×10^{-11} cm for r_e , $q_e = 4.7326 \times 10^{-10}$ cm³/s against the experimental value of 4.8×10^{-10} CGSE. Nearness of the theoretical value with the experimental value is striking!

An electron moving away from an observer (electron axis coinciding with the line of motion) is seen as a positron by another observer to whom this electron is approaching. Figure 4 shows, qualitatively, attractive and repulsive forces between these particles through interaction of their velocity fields, while quantitative relationships follow. In (a) of Fig. 4, the velocity-field u between particles is increased due to the superposition of the fields. From Eq. (2), an increase in u results in a proportionate decrease of r , and hence the particles are brought closer by an attractive force between them. In (b) of Fig. 4, due to the decrease of the velocity field between the particles, r has to increase proportionately, and this causes a repulsive force between similar particles. Quantitative relationships are derived in Sec. IV.

IV. FUNDAMENTAL MASS

The property of mass in the fundamental particle of matter (electron) arises due to the breakdown of vacuum circulation at the center of the electron, and the consequent creation of a dynamically stable spherical void, associated with gravitational as well as electrostatic fields in space. The derivation of the mass of the electron from the vortex structure is as follows (refer to Fig. 3). Consider an element of void volume,

dV , within the spherical interface: $dV = (\pi r_e^2 \sin^2 \theta) r_e d\theta = \pi r_e^3 \sin^2 \theta d\theta$. The tangential velocity of the vacuum space acting at the interface of this element is $\dot{\varphi} r_e \sin \theta$. The physical process of creation of mass, dm , of this element is due to the volume dV of the vacuum space being pushed out at the time of void creation at the speed $\omega r_e \sin \theta$ tangentially through the interface. The mass of the elemental void volume is defined from *first principles* below:

$$dm = dV(\omega r_e \sin \theta) = dV(c \sin \theta).$$

Substituting the value of dV from above, $dm = \pi r_e^3 \sin^2 \theta d\theta \omega r_e \sin \theta = (4\pi/3)r_e^3 c$.

Integrating for the total mass m_e , varying θ from 0 to π

$$m_e = (4\pi/3)r_e^3 c. \tag{6}$$

Fundamental mass

$$= \text{Fundamental void volume} \times c. \tag{7}$$

The volume-integral of the vacuum-circulation velocity within the void, at the instant of its creation, is the mass of the fundamental unit of matter (electron).

The void at the electron center is dynamically stable with radius r_e and vacuum circulation at c . This leads to the creation of only one size of stable void. Therefore all the particles of matter, nuclei and atoms will have their masses in exact multiples of electron mass. The mass of the electron during motion relative to space will remain constant up to speed c because the fluid-space ahead of a moving electron can be displaced up to a maximum speed c only. Thus, the volume of the void remains constant; therefore, electron mass, which is proportional to the volume of the void [Eq. (7)], also remains constant. The relativistic increase in electron mass at speeds closer to light speed, as experimentally observed, is due to the reaction of the fluid vacuum space against the interface in the electron’s structure, resulting in the production of an additional acceleration field.³ The proportionality of mass to the limiting velocity field c and also to the volume of the central void [Eq. (6)] shows that

mass is not energy. “Mass is proportional to energy” is a more accurate statement.

A. Dimensions and the unit of mass

The dimensions of mass from Eq. (6) are: $m_e = L^4/T$. Therefore, in the CGS system of units, the unit of mass is: cm^4/s . With the use of the experimentally determined mass of the electron, the computed mass of a molecule of water, and the known numbers of molecules in one cm^3 of water, the relationship between “ cm^4/s ” and “gram” is determined, approximately, as below.

From the charge equation (4), the electron radius is

$$r_e = (q_e/\pi^2 c)^{1/2}. \quad (8)$$

The electron charge is experimentally determined as 4.8×10^{-10} CGSE. Expressing CGSE as cm^3/s from Eq. (5), $q_e = 4.8 \times 10^{-10} \text{cm}^3/\text{s}$, and substituting this value of electron charge and the value of c in Eq. (8), we obtain

$$r_e = \frac{(4.8 \times 10^{-10} \text{cm}^3/\text{s})^{1/2}}{(\pi^2 3 \times 10^{10} \text{cm}/\text{s})^{1/2}} = 4 \times 10^{-11} \text{cm}. \quad (9)$$

With the above radius of the interface enclosing the void, its volume is $V_e = (4\pi/3)(4 \times 10^{-11} \text{cm})^3 = 2.67 \times 10^{-31} \text{cm}^3$. The mass of the electron, experimentally determined, is 9.11×10^{-28} g. Although the concept of density in its structure is not applicable because of the central void, the ratio of the “electron mass” and the “volume of its void” will be indicative of the proportionality of the “quantity of mass” within a “unit volume of void”. From above, this ratio, m_e/V_e is $9.11 \times 10^{-28} \text{g} / 2.67 \times 10^{-31} \text{cm}^3 = 3.42 \times 10^3 \text{g}/\text{cm}^3$. And gram is

$$\text{Gram} = 8.4 \times 10^6 \text{cm}^4/\text{s}. \quad (10)$$

Alternatively, the above relationship can also be found as follows.

Substituting the values of electron radius r_e from Eq. (9) and the experimentally determined mass in mass equation (6), we have: $9.11 \times 10^{-28} \text{g} = (4\pi/3) (4 \times 10^{-11} \text{cm})^3 (3 \times 10^{10} \text{cm}/\text{s})$. From which

$$\text{Gram} = 8.8 \times 10^6 \text{cm}^4/\text{s}. \quad (11)$$

The results obtained in Eqs. (10) and (11) are close; from the average of both

$$\text{Gram} \approx 8.6 \times 10^6 \text{cm}^4/\text{s}. \quad (12)$$

V. ENERGY IN ELECTRON STRUCTURE. THE LINEAR AND ACCELERATING-MOTION OF VACUUM ARE THE BASIC STATES OF ENERGY

The circulation of vacuum, forming the electron’s interface and spreading throughout the universal space, is the structural energy of the electron; it is computed as follows.

Refer to Fig. 3. Consider, within the interface, an elemental “disk of void” of volume $dV = (\pi r_e^2 \sin^2 \theta) r_e d\theta = \pi r_e^3 \sin^2 \theta d\theta$, which is created due to the displacement of the vacuum through the interface at the tangential velocity, $\omega r_e \sin \theta$, or, $c \sin \theta$ [since from Eq. (3) $\omega r_e = c$] at the instant of the electron’s creation. The mass of this is

$$\begin{aligned} dm &= dV(c \sin \theta) \\ &= (\pi r_e^3 \sin^2 \theta d\theta)(c \sin \theta) = \pi c r_e^3 \sin^3 \theta d\theta. \end{aligned} \quad (13)$$

The disk element has an area at the interface equal to $(2\pi r_e \sin \theta) r_e d\theta$; and has an inward radial acceleration field at each point on it such that $a_r = \omega^2 r_e^2 \sin^2 \theta / r_e \sin \theta = c^2 \sin \theta / r_e$.

Consider the process opposite to void creation: the case of collapse of the interface to zero radius, when each point at the interface of the elemental disk will be displaced along the radius $r_e \sin \theta$ with the above inward acceleration field acting on it. The energy released due to collapse of the void-disk-element is defined as

$$\begin{aligned} dE &= dm a_r (\text{field displacement}) \\ &= (\pi c r_e^3 \sin^3 \theta d\theta) (c^2 \sin \theta / r_e) r_e \sin \theta = \pi c^3 r_e^3 \sin^5 \theta d\theta. \end{aligned}$$

Integrating, varying θ from 0 to π , to obtain the total energy released due to the collapse of the spherical void yields the creation energy

$$E = (4/5)(4\pi r_e^3 c/3)c^2 = (4/5)m_e c^2, \quad (14)$$

which is close to the mass-energy-equation of relativity theory if $(4\pi r_e^3 c/3)$ is replaced by m_e , as per mass equation (6).

The physical reason as to why the speed of light c appears in Einstein’s mass energy equation is now explained. It signifies the actual maximum possible vacuum-circulation in the structure of fundamental matter, even when matter is stationary relative to the medium of vacuum-space.⁵

A. Angular momentum of electron vortex

The intrinsic angular momentum of the spinning interface of the electron is found as follows, refer to Fig. 3. Consider an element of void-volume $dV = \pi r_e^2 \sin^2 \theta r_e d\theta$, which, at the interface, has the tangential velocity of vacuum space, $\omega r_e \sin \theta$. Its mass from Eq. (6) will be $dm = dV \omega r_e \sin \theta = (\pi r_e^3 \sin^2 \theta d\theta) c \sin \theta = \pi c r_e^3 \sin^3 \theta d\theta$ and angular momentum, $dL = dm (\omega r_e \sin \theta) r_e \sin \theta = (\pi c r_e^3 \sin^3 \theta d\theta) c r_e \sin^2 \theta = \pi c^2 r_e^4 \sin^5 \theta d\theta$. Integrating, varying θ from 0 to π , to obtain the angular momentum for the whole interface, we obtain

$$\begin{aligned} L &= \pi c^2 r_e^4 \sin^5 \theta d\theta \\ &= (4/5)[(4\pi/3)r_e^3 c] c r_e = (4/5)m_e c r_e, \end{aligned} \quad (15)$$

in which m_e has been substituted for the quantity within the bracket as per the mass-equation (6).

The intrinsic angular momentum of the electron is directly proportional to its mass, radius, and the speed of light.

B. Spin magnetic moment

Refer to Fig. 3. Consider an infinitesimal ring-element of charge $dq = dA \omega r_e \sin \theta$. The Magnetic moment due to this charge element is defined as:

$d\mu = dq (\omega r_e \sin \theta) r_e \sin \theta = (2\pi r_e \sin \theta r_e d\theta) (\omega r_e \sin \theta) (\omega r_e \sin \theta) r_e \sin \theta = 2 \pi c^2 r_e^3 \sin^4 \theta d\theta$. Integrating, varying θ from 0 to π to obtain total magnetic moment of the electron, we obtain

$$\begin{aligned} \mu &= (2\pi c^2 r_e^3)(3\pi/8) \\ &= (3/4)(\pi/4)(4\pi r_e^2 c) cr_e = (3/4)q_e cr_e. \end{aligned} \tag{16}$$

The magnetic moment of electron is directly proportional to its charge, radius, and speed of light.

VI. ELECTROSTATIC FIELD ENERGY

An expression for the electrostatic field of the electron at a point in space is derived below from the vortex structure of the electron, refer to Fig. 5. Consider a sphere of radius r , cut by a diametrical plane parallel to the X-Z, containing a circle C of radius $p_1 y_1$. The planes of the circles c_1 and c are also parallel to X-Z. The radius r (op_1) passes through the interface of the electron at point p , and meets C at p_1 . In the diametrical plane Z, the point z at the interface will have a tangential velocity of vacuum space ωr_e , that is c (down the paper); the tangential velocity of vacuum at the point z_1 down the paper, from Eq. (2), will be cr_e/r . The velocity of vacuum u_2 , at p , tangential to the circle C_1 , is $\omega r_e \sin \theta$, whereas, at p_1 tangential to the circle C, the velocity of space from Eq. (2) is $u_1 = (\omega r_e \sin \theta) r_e \sin \theta / r \sin \theta = cr_e \sin \theta / r$. The inward acceleration field at p_1 , along $p_1 y_1$ is

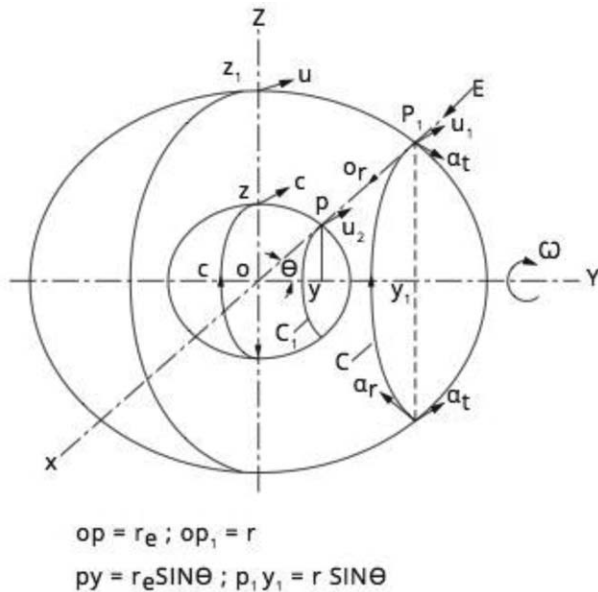

FIG. 5. Electric field of electron.

$$a_f = \frac{u_1^2}{r \sin \theta} = \frac{(cr_e \sin \theta / r)^2}{r \sin \theta} = \frac{c^2 r_e^2 \sin \theta}{r^3}, \tag{17}$$

p , tangential to the circle C_1 , is $\omega r_e \sin \theta$.

The component of a_f along the radius op_1 from Eq. (17) is $a_r = a_f \sin \theta = c^2 r_e^2 \sin^2 \theta / r^3$. The electric field E at p_1 along the radius op_1 is defined to have the following relationship with the radial space acceleration field a_r , derived above:

$$\begin{aligned} \frac{dE}{dr} &= a_r \\ &= \frac{c^2 r_e^2 \sin^2 \theta}{r^3} \text{ from which } E = \frac{-c^2 r_e^2 \sin^2 \theta}{2r^2}, \end{aligned} \tag{18}$$

which is an inward field created by the electron (also by a positron, if the same is considered) with the minimum value of r equal to r_e , because the void is field-less.

The magnitude of E at the interface, along the y-axis, for $\theta = 0$, is zero; and in the transverse plane (E_{tr}) for $\theta = \pi/2$, at the point z_1 distant r from the origin is

$$E_{tr} = \frac{-c^2 r_e^2}{2r^2} e. \tag{19}$$

The maximum value of E is at the interface in the transverse plane Y-Z for $\theta = \pi/2$, and $r = r_e$

$$E_{\max} = -\frac{c^2}{2}. \tag{20}$$

The electric potential ϕ at z_1 from Eq. (19) is given by $d\phi/dr = E_{tr}$, from which, $d\phi = E_{tr} dr = (c^2 r_e^2 / 2r^2) dr$, and $\phi = -c^2 r_e^2 / 2r$. In an irrotational vortex, from Eq. (2), $cr_e = ur$. Substituting this in the above equation, we have

$$\phi = \frac{-cr_e(ur)}{2} = \frac{-cr_e u}{2}. \tag{21}$$

From Eq. (21), it is seen that in a vacuum vortex, the velocity field u , is the most fundamental field in the universe, which creates the electrostatic potential.

Attraction between an electron and a positron [Fig. 4(a)] can be calculated by using Coulomb's equation for interaction between charges with the concept of the electric field derived above, and also explained through superposition of velocity fields, as stated earlier.

Coulomb's law, which was experimentally determined, can be derived from Eq. (19) as follows.

Multiplying and dividing the right-hand side of Eq. (19) by $(\pi/4)4\pi$ and rearranging terms

$$E_{tr} = -c^2 r_e^2 (\pi/4) 4\pi / 2r^2 (\pi/4) 4\pi = -2c [4\pi r_e^2 c (\pi/4)] / (4\pi r^2).$$

Replacing the quantity in the brackets by q_e from the charge equation (4), we have

$$E_{tr} = \frac{-2/\pi \left(\frac{c}{4\pi}\right) q_e}{r^2}. \tag{22}$$

The above equation shows that the electric field, that is, "force per unit charge," is directly proportional to the charge, and inversely proportional to the square of the distance from

the charge, in agreement with Coulomb's law. For spherically symmetric charge distribution is

$$E = \frac{(1/4\pi \epsilon_0)q_e}{r^2}. \quad (23)$$

A. Dielectric constant, permeability constant, Gauss' law

Using Eqs. (20) and (23), and charge equation (4), we derive the dielectric constant of the vacuum³ as

$$\epsilon_0 = \frac{\pi}{2c}. \quad (24)$$

The vacuum dielectric constant is inversely proportional to the speed of light.

A check can be made for the above equation by substituting $\pi/2c$ in Eq. (23) in place of ϵ_0 , yielding $E = 1/4\pi (\pi/2c) q_e/r^2 = (c/2\pi^2) q_e/r^2$. Expressing q_e in CGSE and inserting the value of c ,

$$E = \left[(3 \times 10^{10} \text{cm/s})/2 \times (3.14)^2 \right] 4.8 \\ \times 10^{-10} \text{CGSE}/r^2 = (0.73) \text{CGSE}/r^2.$$

Two CGSE unit charges, located 1 cm apart, require that the above computed coefficient, 0.73, should be 1; the difference is negligible.

From Maxwell's equation, it follows that $c = 1/(\mu_0 \epsilon_0)^{1/2}$, where μ_0 is the permeability constant of the vacuum. (From this basic relationship, it was possible to predict that light is an electromagnetic effect). When ϵ_0 is expressed in terms of c as derived in Eq. (24), the above equation becomes $c = 1/(\mu_0 \pi/2c)^{1/2}$; from which we have

$$\mu_0 = 2/\pi c. \quad (25)$$

It is seen that like the dielectric constant, the permeability constant of the vacuum is also inversely proportional to the speed of light.

B. Electrostatic energy in electron vortex

The electrostatic energy U in the velocity field of the electron vortex is calculated³ from the electric field Eq. (18), the dielectric constant Eq. (24), and mass equation (6), as

$$U = (\pi/10)m_e c^2. \quad (26)$$

In the integral to compute the above energy U , the lower limit of the radius from the electron center is the interface radius r_e of the electron, not zero, as is the case with a point-charge, which would lead to infinite energy in its electrostatic field. The electrostatic energy Eq. (26) is less than the total electron creation energy in space derived in the mass-energy equation Eq. (14). The difference [about $(1/2) m_e c^2$], should appear as the electron's gravitational energy in space.

VII. ATOMIC STRUCTURE

A. Basic principles

The limitation on the creation of only one size of stable void in the space vortex, that produces stable fundamental mass and charge as basic units, very much simplifies the theory of atomic structure. It follows that stable particles will possess mass in exact multiple of electron mass—there being no difference between the rest-mass and the relativistic-mass. Further, no stable particle with mass less than electron mass shall ever be found, either, naturally, or, created through artificial means in a laboratory. The unstable particles with mass larger than the electron mass are the “intermediate stages” in the formation of stable particles like neutron and proton; and do not merit considerations as the building blocks of stable particles.⁵

The stable particles that show the property of electric charge, such as proton, alpha particle, etc., are enclosed within space-vortices, which create stable charges on them. The unstable particles, showing charge property, may also be enclosed within space vortices of varying strengths, for their lifetime duration. A neutral particle, such as a neutron, does not possess space vortex around it, and hence, without an electric charge, it remains neutral.

All stable particles, neutral or charged, will have their spin-axes of rotation. The charge of a particle, from charge equation, will be in direct proportion to its nuclear surface and the maximum speed of space-circulation in its vortex at the nucleuse.

An electron and a positron in close range will undergo annihilation, unless, the particles are translating *relative to vacuum space* and, thereby, producing magnetic force of repulsion between them.

Just as an electron is subjected to an “inward acceleration field” on its interface, all charged particles and nuclei, with space-circulation around them, will have “inward acceleration field” tending to crush the particles. With the above guiding principles, the possible structure of the nuclear particles is outlined below.

B. Neutron

In Fig. 6, an assembly of two electrons and two positrons is shown. The velocity fields of the particles are in opposition in the region external to the assembly and, therefore, this assembly (named as “primary unit”) will show overall electrical neutrality. The particles repel diagonally due to similar charges, whereas, there is attraction between the adjacent particles due to dissimilar charges. In addition, if the particles are also spinning around a center as shown in Fig. 6, there will be a radial force, $m_e v^2/r$, which will reinforce the diagonal electrostatic repulsive force F_r . If the component of F_r balances the attractive force F_a due to attraction between the electron and the adjacent positron, the primary unit will be stable. The forces in the primary unit are computed.³ Also, since positron is not found as electron, electrons reversed to 180° are to be treated as positrons in Fig. 6, and also in Fig. 7.

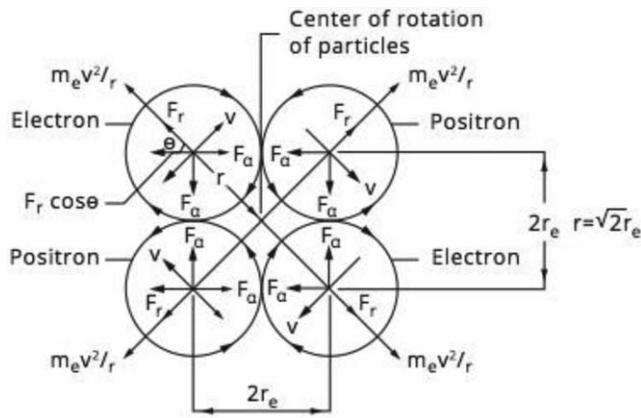

FIG. 6. Primary unit.

The primary units can exist in fours. The overall vortices provide electric charge and an inward acceleration-field on the surface of the primary units, thus making them stable building blocks of matter in the core of the neutron. Just as the electrons and positrons assemble primary units, these units, charged positively and negatively, can assemble the neutron core.^{6,7-14}

Consider a spherical assembly of equal nos. of electrons and positrons with a total of n particles. The radius of this assembly

$$r_n = (n)^{1/3} r_e. \tag{27}$$

If this assembly is of neutron, its known mass is 1839 me. Since neutron is a neutral particle, it will possess equal nos. of electrons and positrons, because the superposition of the velocity fields of equal nos. of these particles will bring overall neutrality. Therefore, neutron should have 919 nos. of electrons and equal nos. of positrons. The radius of neutron

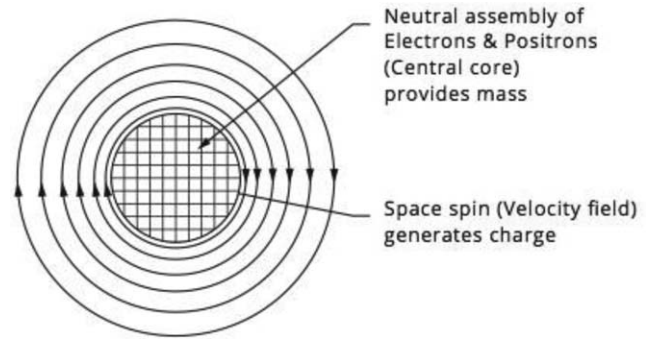

FIG. 8. Proton with the core of neutron.

$$r_n = (1838)^{1/3} r_e \approx 12r_e. \tag{28}$$

If the neutron, without a vortex enclosing it, rotates on an axis through its center at speed c at its periphery, it will account for its maximum possible angular momentum. A primary unit or its constituents (electron/positron) may be dislodged due to outward centrifugal force, and emitted out. This explains as to why neutron has a short half-life of about 15 min.⁶

C. Proton and hydrogen atom

The structure of proton contains a neutron enclosed within a space-vortex (Fig. 8), which accounts for the charge of proton and, in addition, creates an inward acceleration field. In proton structure, the inward acceleration field on the neutron's surface makes the proton an ultra stable particle. Similar to the electron, the proton too has its maximum velocity field confined within the diametrical plane at right angles to the axis of rotation; and, therefore, its electromagnetic interactions with other particles will take place in this plane.

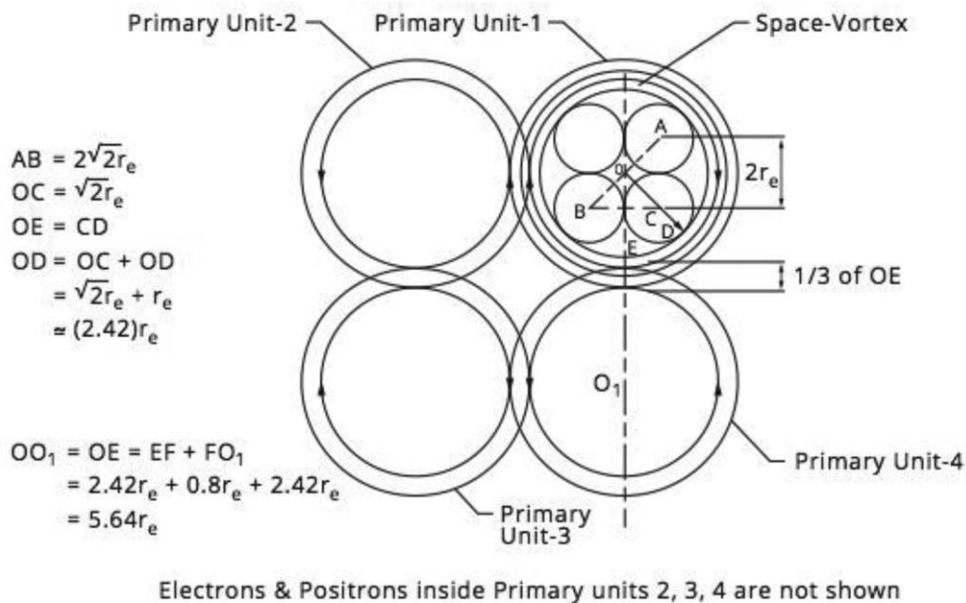

FIG. 7. Primary units enclosed within space vortices.

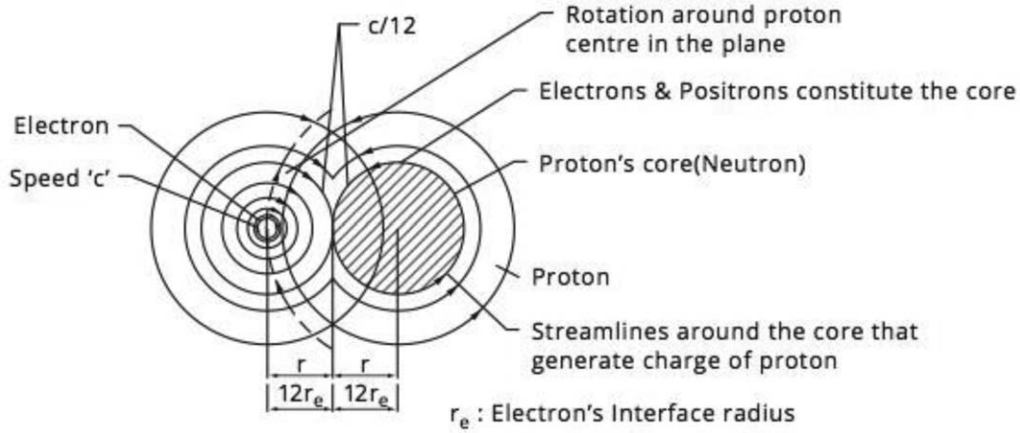

FIG. 9. Hydrogen atom.

From Eq. (28), radius of neutron (core of proton), $r_n = 12 r_e$; From Eq. (2) for an irrotational vortex: $ur = \text{constant}$. Therefore, maximum tangential velocity of space at the surface of the neutron/proton core in the diametrical plane is found from $u_p r_n = c r_e$, where c is the tangential velocity at the interface of electron of radius r_e .

From this

$$u_p = cr_e/r_n = cr_e/12r_e = c/12. \quad (29)$$

The electric charge of proton due to u_p is computed from a relationship similar to the charge equation (4), as

$$\begin{aligned} q_p &= (\pi/4)4\pi r_n^2 u_p \\ &= (\pi/4)4\pi(12r_e)^2 c/12 = 12\pi^2 r_e^2 c, \end{aligned} \quad (30)$$

which is 12 times the electron charge. The reason as to why a Hydrogen atom (Fig. 9), which has a proton and an electron,^{6,7} shows neutrality is due to the cancellation of their magnetic moments as shown below.

The orbiting electron is that far located so as to reduce its velocity field to the same value as at the surface of the proton core

$$cr_e = (c/12)r_n$$

or

$$r_n = 12r_e, \quad (31)$$

where $2r_n$ is the radius of the electron orbit.

The magnetic moment of the orbital electron is due to its intrinsic spin (16) and also its orbital velocity v_{orb} . Total of magnetic moments is

$$\begin{aligned} \mu_e &= (3/4)q_e cr_e + q_e v_{\text{orb}}(12r_e + 12r_e)/2 \\ &= q_e r_e [(3c/4) + 12v_{\text{orb}}]. \end{aligned} \quad (32)$$

Intrinsic magnetic moment of proton, from an expression similar to the electron (16), is

$$\mu_p = (3/4)[q_p(c/12)12r_e]. \quad (33)$$

Substituting, $q_p = 12 q_e$, from Eq. (30)

$$\mu_p = (3/4)[12q_e(c/12)12r_e] = 9q_e cr_e. \quad (34)$$

Equating the magnetic moment of electron (16) with the magnetic moment of the proton (34), in order to achieve neutrality of the Hydrogen atom

$$q_e r_e [(3c/4) + 12v_{\text{orb}}] = 9q_e cr_e,$$

which gives,

$$v_{\text{orb}} = 0.69c. \quad (35)$$

In a Hydrogen atom, the radius of the electron orbit is $24r_e$, that is about 10^{-9} cm; and its orbital velocity is 69% of the speed of light. With this high rotational speed, the electron completes one orbit in a time duration of: $(2\pi) 10^{-9}$ cm / $(0.69) 3 \times 10^{10}$ cm/s, that is, 3×10^{-19} s, providing an outer shield to the atom with its spinning interface that cannot be penetrated-through. The binding force provided by the velocity fields of the oppositely spinning vortices of the orbital electron and the proton, maintains the assembly with no energy loss from the system, since the vortices are formed in the nonviscous space.

The nucleus of Hydrogen atom (neutron within proton vortex) has an inward acceleration field of strength: $(c/12)^2/12r_e$, that is, $(1/12)^3 c^2/r_e$. This inward field, which is $(1/12)^3$ times less than the maximum possible field (c^2/r_e) on the interface of the electron, makes it a highly stable particle, as stated before.

Structures of atoms higher than Hydrogen are given in Refs. 3 and 4.

The space-vortex structure of the electron and the proton, enclosed within their overall space-vortices, can assemble an alpha particle. When several alpha particles are assembled, with four in each unit (similar to the assembly of primary units in the neutron structure), and enclosed within an outer vortex, all nuclei of atomic mass higher than helium can be built. This process requires that nuclei should have equal numbers of neutrons and protons, which, however, is not the case. For example, the ratio of neutrons to protons in the Uranium nucleus is 1.586. This leads to the conclusion

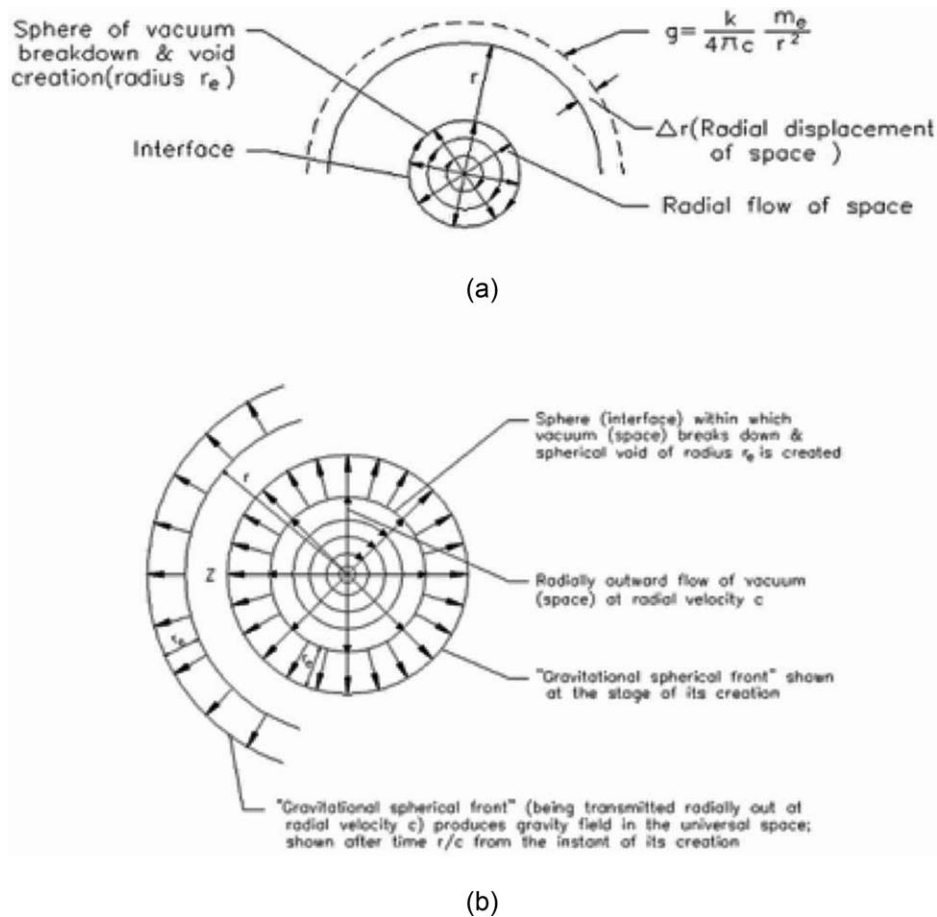

FIG. 10. (a) Gravitational effect: Sphere of void creation and (b) gravitational spherical front.

that, in addition to the alpha particles, neutrons are also *independently* present, as required by the atomic masses of the nuclei. The emission of alpha particles from radioactive nuclei provides solid proof of their existence within nuclei in an independent condition. The presence of electrons and positrons in nuclei is confirmed by beta particle radiation. For simplicity in the analysis of the stability of nuclear structure, we can assume that protons and neutrons exist independently in a dynamic assembly, and each proton exerts a repulsive force on the rest of the protons in the nucleus, which is enclosed within an outer space-vortex.³ The space-vortex enclosing the nucleus creates an inward field acting on the nucleus, and it has a maximum value in the diametrical plane at right angles to the axis of rotation of the nucleus; given by u_n^2/r_n , where u_n is the tangential velocity of space at the nuclear surface in the diametrical plane, transverse to the axis of rotation, and r_n is the nuclear radius.⁷

Since from Eq. (2), u_n varies inversely as r_n , the inward acceleration field on the nucleus falls inversely as $r_n^{1/3}$. The outward electrical repulsive forces within the nucleus trying to disrupt its structure (due to the presence of protons) fall inversely as the square of r_n . Since the inward acceleration field falls faster, nuclei with more protons and a larger radius become radioactive. By equating the outward electrical force in the nucleus with the inward force, it is concluded³ that *stable* nuclei with protons more than 100 cannot exist in nature.

VIII. GRAVITATION

Gravitational effects arise from the very structure of the electron. As a result of creation of the spherical void at the electron center due to the limiting speed of space-circulation, universal space is gravitationally energized [Figs. 10(a) and 10(b)] through the transmission of gravitational potential; a process starting from the interface of the electron and proceeding outward at speed c , the limiting speed for transmission of fields/potentials in space. The energy used to create each electron is retained in space as gravitational/electrostatic potential, there being no reduction in the overall content of the universal energy due to creation of electrons. The creation of electron voids requires energy (14) of magnitude $(4/5) m_e c^2$ out of which, $(\pi/10) m_e c^2$ is distributed in space as electrostatic energy, whereas, the remainder, about $(1/2) m_e c^2$ stays in space as gravitational potential. As shown in the figure, the gravitational field, g , of the electron is derived³ as

$$g = (k/4\pi c)m_e/r^2, \tag{36}$$

in which k is a “constant of proportionality” with dimensions $1/T^2$, so that the dimensions of g from Eq. (36) are: L/T^2 .

Since the electron is identified as the fundamental particle of matter, Eq. (36) is the equation of the gravity field applicable to all nuclei, atoms and matter in general.

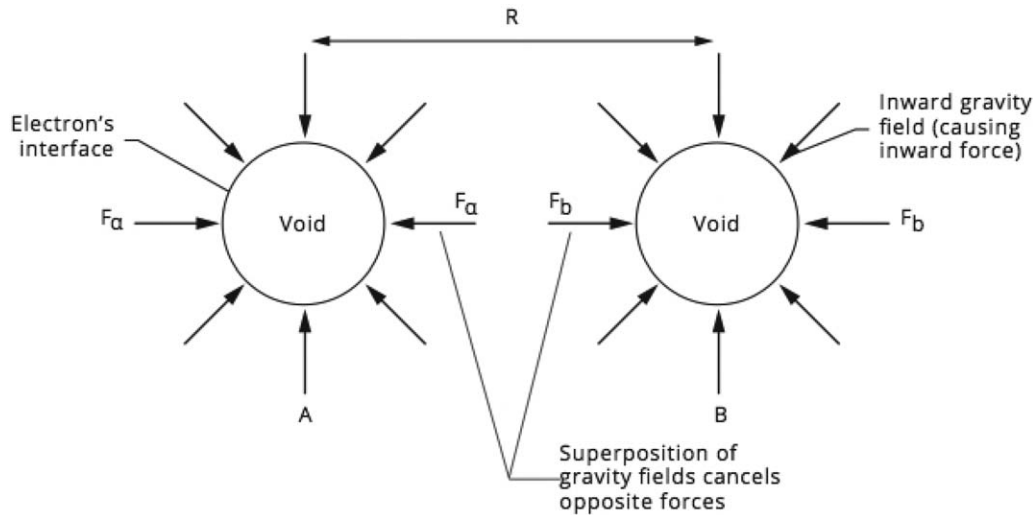

FIG. 11. Gravitational Interaction—Stationary electrons.

Gravitational constant for an atom of average atomic mass has been derived.³

A. Gravitational interaction

Consider two stationary electrons A and B with an in-between distance R (Fig. 11). Suppose that the electrons are not influenced by any external field except their own gravity fields, neglecting for the present their electric field, also. The superposition of the inward fields between the particles, partially nullifies the fields; due to which the outer fields exert forces (F_a , F_b) which will push the particles closer. Now, consider a case when the above two particles come into existence at different times. Let A be created at some instant; its gravity field will be transmitted across the distance R after a time R/c , and will continue to traverse further spherically outward at speed c . If B is now created (later than A), its gravity field will reach A after a time R/c , and will gravitationally interact with A, because A, having been created earlier, possesses its gravity field already. Thereafter, as both the particles now have their fields (starting from their interfaces and spread-out, permanently, far in space) in contact with each other, they will have continuous gravitational attraction between them.⁶

IX. COSMIC VORTICES

The vacuum vortex structure of the electron repeats in identical patterns in the structures of the planets, stars, and galaxies too. There are vacuum space vortices enclosing, individually, all the cosmic bodies with axial rotation. These vortex circulations perform several functions, such as: creating surface gravity, causing axial rotation, producing electrical charge on the surface of the cosmic bodies, and also producing electrical charge and electrical forces of attractive and repulsive nature, between them. Another striking similarity between the fundamental matter and the planets/stars/galaxies is in their material structure. The discrete (independent) volumes of the voids in the structure of the electrons and positrons that constitute nuclei/atoms, and assemble into

cosmic bodies, when summed up mathematically, amount to a large volume of void, in proportion to the mass of the cosmic bodies. This volume of void is enclosed within the vacuum space vortex; just as a single electron's central void is enclosed within a vacuum space vortex.^{6,7}

High velocity fields in the vortices around the cosmic bodies cause their axial rotation perpetually due to zero viscosity of space. The orbital-motion of the satellites, planets and stars, around their respective primaries, are also caused by the velocity fields of cosmic vortices. Taking the example of the solar system, it is explained below that the orderly orbital motion of the planets and satellites is the result of the regulation by the velocity fields in the solar space vortex.

X. ANNIHILATION OF ELECTRONS AND POSITRONS—THE FUNDAMENTAL NATURE OF LIGHT

With the discovery of the positron (1932), a new phenomenon of the annihilation of electrons and positrons was observed. During this process, the spherical interfaces of the particles, under strong electrical attraction, are brought together, and, at a very close range, the particles superimpose on each other; thus stopping the oppositely directed space-circulations around their interfaces, which leads to a collapse of their central voids. In this process, mass vanishes and light is produced. It is evident that the void interiors within the interfaces of the electron and positron, being energy-less, cannot emit any kind of energy (such as photons). The energy (velocity and acceleration fields) in the vortex structure of these particles pervades the whole of universal space before annihilation. Following annihilation [Fig. 12(a)], the process in which the electromagnetic and gravitational potentials are reduced to zero, a single shell of light, seen as a pulse, initiates from the superimposed interfaces [Fig. 12(b)]. When the interfaces of the particles superimpose, there is only one spherical void common to both particles; space flows radially at its maximum speed c into the void [Fig. 12(b)].

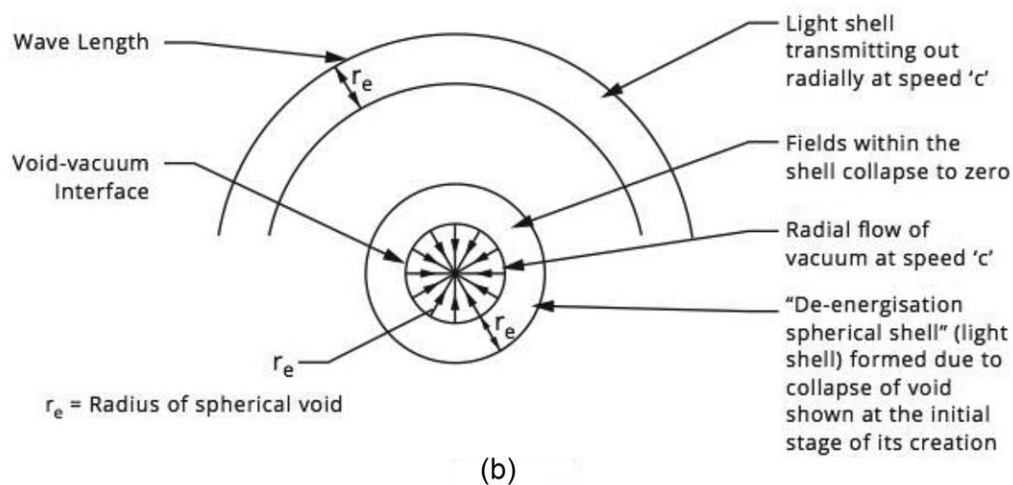
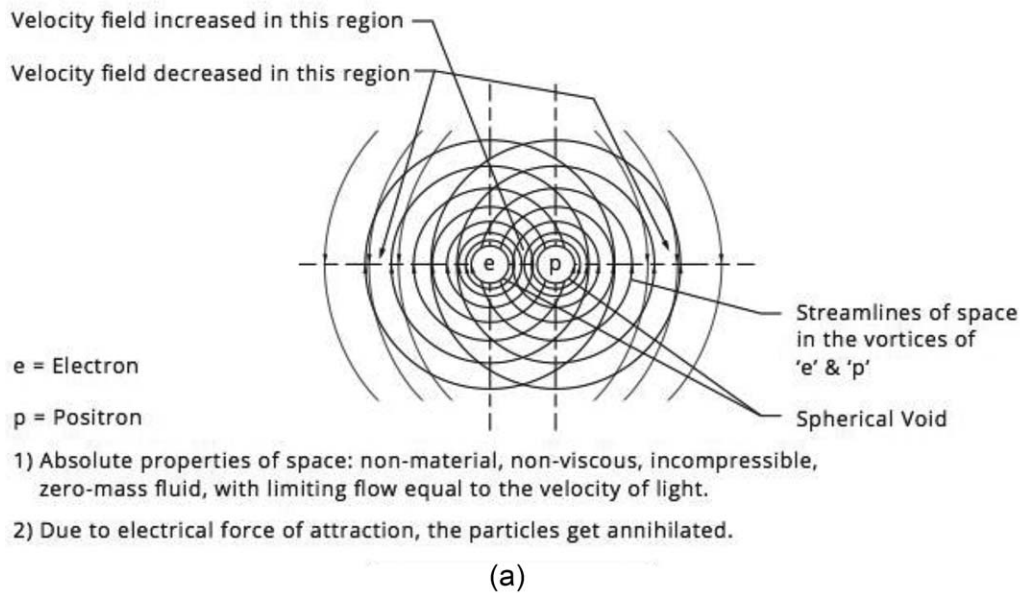

FIG. 12. (a) Annihilation of electron and (b) following electron's annihilation.

The duration of collapse is $\Delta t = r_e/c$. During this period, a shell of radial width, $\Delta t \times c$, that is, $(r_e/c) c = r_e$, depleted in energy (zero potential) is formed around the interface, and transmitted outward at speed c relative to the vacuum space.³ The transmission of the shell is a process that de-energizes the vacuum space medium, erasing for all time the gravitational and electrostatic potentials that were created at the time of the creation of the now nonexistent electron and positron.⁵

The spherical shell produced due to dying of potentials, a process of de-energizing of the space substratum following the electron/positron annihilation, is the fundamental phenomenon known as light.

The wavelength of the annihilation light [Fig. 12(b)] is equal to the electron radius. The interrelationship between light and gravity, and derivation of the gravitational and Planck constants have been analyzed in Ref. 3.

The gravitational field of electron is radial and uniformly distributed on its interface. Therefore, the effect of light due to dying-gravitational-potential will have spherical symmetry. Maximum electrostatic fields of these particles are confined mostly to the diametrical plane at right angles to the axis of rotation; hence, maximum effect of light produced due to dying-electrostatic-potential will be confined within this plane.^{6,7}

XI. WAVELENGTH AND FREQUENCY

The wavelength of annihilation light Fig. 12(b) is equal to the electron radius. This light, with a single shell, does not have the concept of frequency applicable to it. In case there are several annihilations taking place at a point, one after the other, without absolutely any time gap between the successive annihilations, then the frequency can be defined as nos.

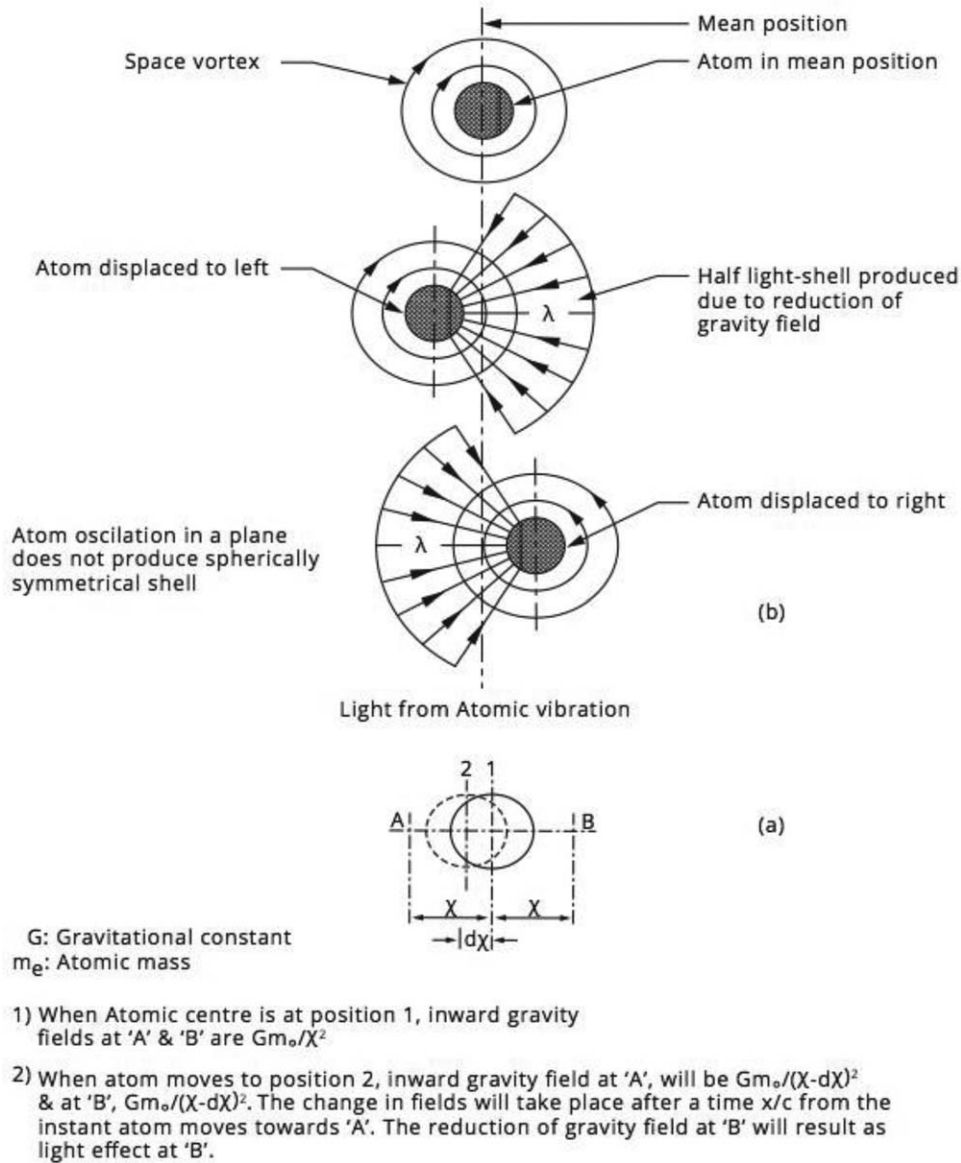

FIG. 13. Light from atomic vibration.

of shells formed in unit time. Also, if the time for the formation of a single shell is Δt , then frequency f can be defined as: $f = 1/\Delta t$, keeping in mind, however, that this mathematical operation does not mean that the single-shell-light has the property of frequency as per the conventional definition of frequency ($f = c/\lambda$). In case of light produced due to atomic vibration (Fig. 13), the frequency of light is determined by the nos. of atomic oscillations in unit time, assuming that the oscillations are continuous. The shells of light produced in annihilation as well as atomic vibration have their centers fixed with the source (assumed stationary relative to space), while the wave front with a fixed radial distance within each shell (wavelength) transmits at speed c relative to space.

XII. PLANCK ENERGY EQUATION

Based on the concepts of Maxwell-Hertz, that electromagnetic (light) energy is given off from electrical oscillators, Plank believed that the orbiting electrons inside the

atoms of a glowing solid-emitter radiated electromagnetic waves in different quantities; the frequency being determined by the vibration of the oscillator. The classical picture was revised by Planck based on his observed experimental fact, when he assumed that an oscillator, at any instant, could have its total energy (potential, kinetic) only as an integral multiple of the energy quantity hf , where h is a universal constant (experimentally determined) and f is the frequency of vibration of the oscillator. Thus, the light energy can be absorbed or emitted in an *indivisible* quantum of magnitude hf .

A. Interaction of orbital electrons in an atom with a wave-pulse (shell) of light

With the nuclear structure described earlier, the nuclear radius of an average atom (120 times proton mass) is computed³ as $r_n = 2.37 \times 10^{-9}$ cm. The maximum velocity field at the nuclear interface is $u_n = 5 \times 10^8$ cm/s. In the atomic vortex around the nucleus, this velocity field will fall

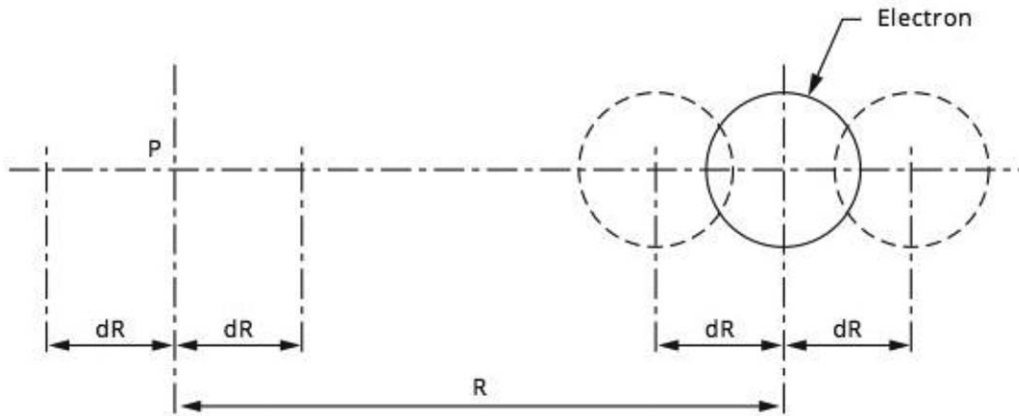

FIG. 14. Oscillating electron.

off inversely with distance to $v = 1.2 \times 10^8$ cm/s at a radial distance of 10^{-8} cm, which is known to be the orbital radius of the outermost electron. The orbital electrons in the space vortex will be subjected to an inward acceleration field $a_f = v^2/\text{orbital radius} = (1.2 \times 10^8 \text{ cm/s})^2/10^{-8} \text{ cm} = 1.44 \times 10^{24} \text{ cm/s}^2$, due to the positive nucleus.

It has been shown in Eq. (3) that a light shell of wavelength λ , has an acceleration-field a_λ , equal to c^2/λ , across the wavelength directed toward the center of its source. If it meets the orbiting electron at an instant when both the above acceleration fields are in line and the direction of a_f is opposite to that of a_λ , the two acceleration fields will nullify and the electron will be released from the vortex if $a_\lambda = a_f$.

Substituting the values of the acceleration fields, we have $(3 \times 10^{10} \text{ cm/s})^2/\lambda = 1.44 \times 10^{24} \text{ cm/s}^2$, from which $\lambda = 6.25 \times 10^{-4} \text{ cm}$, corresponding to the frequency of 0.48×10^{14} cycles/s. (For metallic sodium, the threshold frequency for the photoelectric effect is about $5 \times 10^{14} \text{ s}^{-1}$).

The orbital electron, moving with velocity v , will be released with the kinetic energy that it already possesses, $E = (1/2) m_e v^2 = (0.5 \times 10^{-28} \text{ g}) (1.2 \times 10^8 \text{ cm/s})^2 = 7.2 \times 10^{-11} \text{ ergs}$. Experiments show that the kinetic energy of photoelectrons is about $8 \times 10^{-11} \text{ ergs}$, very close to the above computed value! Considering the approximate nature of the assumption made as to the electron's orbital radius and computation of the nuclear radius for an atom of average mass, better results could not be expected. It is concluded that light does not impart energy to the orbital electrons for release. The kinetic energy of the released photoelectron is its own energy of motion in the space vortex of an atom. Light cell simply disturbs the stability of the forces under which an electron is stable in its orbit and thus the electrons are released.

B. Interrelationship between light and gravity

Consider an electron oscillating about its center with displacement dR as shown in Fig. 14. At a point P at a distance R from the electron center, where the gravitational field from Eq. (36) is, $G_e m_e^2/R$, the gravitational potential energy is

$$U = G_e m_e^2/R. \tag{37}$$

The oscillation of the electron changes the distance R of P by dR on its either side, due to which the potential U undergoes cyclic changes in its magnitude. The effect of the changes (increase and decrease) of potential starts from the interface of the electron, and transmits to P at speed c . It is this process of “time varying potential” at a point in space, resultant due to the oscillation of electron or atom (analyzed further, that produces light).

$$dU/dR = -G_e m_e^2/R^2 = -G_e m_e(m_e)/R^2. \tag{38}$$

Expressing m_e (in bracket) in terms of r_e and c from Eq. (6); substituting: $k/4 \pi c$ for G_e , and $R = r_e$ to determine the potential gradient at the interface of the electron

$$\begin{aligned} dU/dR &= -(k/4\pi c)m_e[(4\pi/3)r_e^3 c]/r_e^2 \\ &= -k(m_e c r_e)/3. \end{aligned}$$

or,

$$dU/(dR/c) = k(m_e c r_e)/3. \tag{39}$$

The quantity, $dR/c = dt$, is the time duration for the transmission of the potential changes across dR . Multiplying and dividing right hand side of Eq. (39) by $4/5$

$$dU/dt = k(4/5)m_e c r_e(5/4)/3. \tag{40}$$

The quantity, $(4/5) m_e c r_e$, is the angular momentum (L) of electron Eq. (15) derived earlier; its numerical value is found by substituting the known values of m_e , c , and r_e

$$\begin{aligned} L &= (4/5)(9.108 \times 10^{-28} \text{ g})(3 \times 10^{10} \text{ cm/s})4 \times 10^{-11} \text{ cm} \\ &= 0.88 \times 10^{-27} \text{ ergs}. \end{aligned}$$

The dimensions of L are the same as that of Planck constant; also, the numerical value of L for electron, calculated above, is about 7.5 times smaller than the Planck constant: $h = 6.62 \times 10^{-27} \text{ erg s}$.

However, Planck constant was determined in experiment with thermal radiation produced due to atomic vibration, and not with the oscillation of free electron^{b)} being analyzed

^{b)}It is shown further that rotation of electron in atomic orbit is not the basic cause of radiation (production of light).

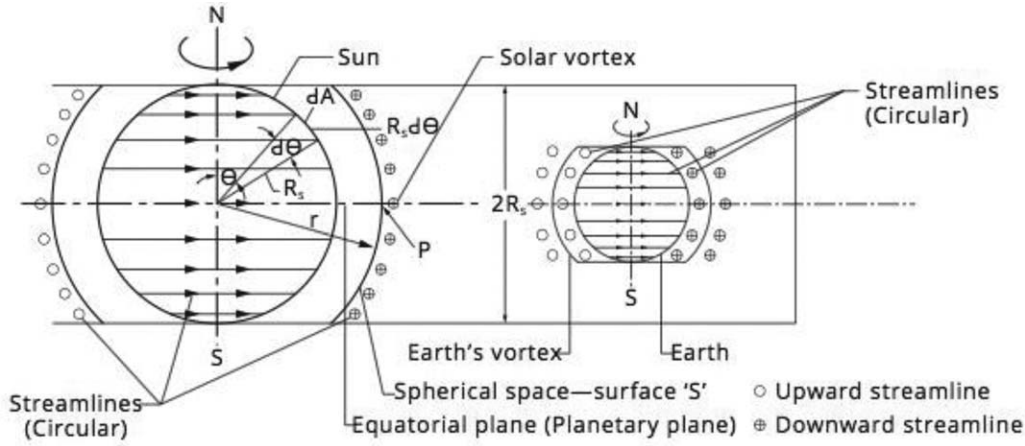

FIG. 15. Solar space vortex—In equatorial plane of sun.

here; therefore, any closer numerical agreement of the values of L and h are not expected. Under these considerations, it is defined that at a point in vacuum space, “time varying gravitational potential” due to oscillation of the electron, produces energy proportional to the Planck constant.

Substituting: $h = (4/5) m_e c r_e$, in Eq. (40), gives the basic equation on the inter-relationship between gravity and light

$$dU/dt = (5k/12)h. \quad (41)$$

C. Planck constant in thermal radiation

The basic-relationship Eq. (41) can be checked by analyzing the oscillation of a single atom as follows:

Let us choose an atom of average atomic weight, say 120 times the proton mass.

Its mass: $m_a = 120 (1.67 \times 10^{-24} \text{ g}) = 2 \times 10^{-22} \text{ g}$, which, from Eq. (12) converting gram into cm^4/s becomes

$$\begin{aligned} m_a &= 120(1.67 \times 10^{-24})(8.6 \times 10^6 \text{ cm}^4/\text{s}) \\ &= 1.72 \times 10^{-15} \text{ cm}^4/\text{s}. \end{aligned} \quad (42)$$

The volume of this nucleus is: $V_n = (4\pi/3) r_n^3$, where r_n is the radius of the nucleus of the atom.

Mass-equation (6), though applicable to the electron in a strict sense, can also be used for the nuclear structure, because the density of distribution of the electrons and positrons in all nuclei will be the maximum. Therefore, from above,

$$V_n = (4\pi/3) r_n^3 = m_a/c, \text{ and, } r_n = (3m_a/4\pi c)^{1/3}.$$

Substituting the value of m_a derived in Eq. (42)

$$\begin{aligned} r_n &= [3 \times 1.72 \times 10^{-15} \text{ cm}^4/\text{s} / 4\pi \times 3 \times 10^{10}]^{1/3} \\ &= 2.39 \times 10^{-9} \text{ cm}. \end{aligned} \quad (43)$$

The gravitational potential energy at the surface of the nucleus

$$U = Gm_a^2/r_n. \quad (44)$$

Substituting the known value of G , m_a and r_n computed above

$$\begin{aligned} U &= 6.67 \times 10^{-8} \text{ g}^{-1} \text{ cm}^3 \text{ s}^{-2} (2 \times 10^{-22} \text{ g})^2 / 2.39 \\ &\times 10^{-9} \text{ cm} = 11.156 \times 10^{-43} \text{ erg}. \end{aligned} \quad (45)$$

Supposing that the average period of oscillation of an atom as 10^{-15} s , the duration (dt) of the change of the gravitational potential at the nuclear surface is $(1/2) 10^{-15} \text{ s}$. Substituting in Eq. (41) the above value of dt and of U computed in Eq. (45)

$$\begin{aligned} dU/dt &= 11.156 \times 10^{-43} \text{ erg} / (1/2) 10^{-15} \text{ s} \\ &= (5/12s^2)h, \end{aligned} \quad (46)$$

from above, $h = 5.36 \times 10^{-27} \text{ erg s}$.

The above result, theoretically obtained, compares close to the experimental value ($6.62 \times 10^{-27} \text{ erg s}$) of h , thus proving that the light-effect at a point in space is produced due to time-varying gravitational potential at that point.

D. Thermal radiation

The velocity field in the vacuum vortex of the average atom is: $v = 1.2 \times 10^8 \text{ cm/s}$ carrying the orbital electrons. With this high velocity, atoms behave like hard particles. Their to and fro oscillations about the mean position is shown in Fig. 13. The oscillations are followed by the trailing fluid vacuum on either side and in opposite directions, thus making the vacuum region around the oscillations highly disturbed. Time varying gravity potential creates one full light cell for each oscillation. Nuclear radius is $2.39 \times 10^{-9} \text{ cm}$. Time for one oscillation with maximum speed of c at which the vacuum can be displaced up to the length of its diameter is, $2 \times 2.39 \times 10^{-9} \text{ cm} / 3 \times 10^{10} \text{ cm} = 1.59 \times 10^{-19} \text{ s}$. During this time one cell of light is formed with a wavelength of: $1.59 \times 10^{-19} \times 3 \times 10^{10} \text{ cm/s} = 4.77 \times 10^9 \text{ cm}$. In black body radiation, oscillators will almost cease at the above frequency, due to reaction from the vacuum fluid space, and the luminosity will come to zero.⁷

PART—II: A dimensional analysis of solar space vortex

XIII. SOLAR SPACE VORTEX

The solar system consisting of the satellites, planets, and the Sun is a large vacuum space vortex with the Sun at its center. Figure 15 shows, partially, the solar space vortex, in the equatorial plane of the Sun, and at right angles to the axis of rotation.

This forms the planetary plane. The velocity field of the space vortex surrounding the Earth, rotates it axially, whereas, the planet Mercury has no vortex around it, for its axial rotation. For simplicity of the sketch, only two planets—Mercury and Earth—are shown (Fig. 16). The other planets too have their respective space vortices within which the satellites are located. The velocity field of the solar vortex carries the planets, and similarly, the satellites are moved by the vortices of their respective planets. Neither the planets, nor the satellites have, normally, relative motion with respect to the medium of space in their immediate vicinity, and hence, their orbital motion does not develop centrifugal force on them. In simple words, the planets are *carried along* by the streamlines of the solar vortex, whereas, the satellites follow, generally, the stream lines of the planetary vortices.

When looked at from the top of the planetary plane, the Sun and the planets rotate anti-clockwise. From this it is inferred that their space vortices, that impart angular momentum to them, also have anti-clockwise rotation. From Fig. 4(a), it is seen that space vortices with opposite rotations attract each other electrically. It, therefore, follows that had there been a planet with axial rotation opposite to the Sun, it would fall on to it under the electrical force of attraction. The repulsive electrical force between the Sun and the planets is calculated.³ However, it can be inferred here that, by and large, in all the star systems in the universe including our own solar system, the axial rotations of the stars and their associated planets have to be in the same direction for the stability of these systems.

A. Velocity field distribution in solar space vortex

Refer to Fig. 15 that shows the Sun’s side view (taken spherical for simplicity) with the radius R_s , and the Earth in the planetary plane, which is transverse to the axis of the Sun’s rotation. The velocity fields in the vortices around the

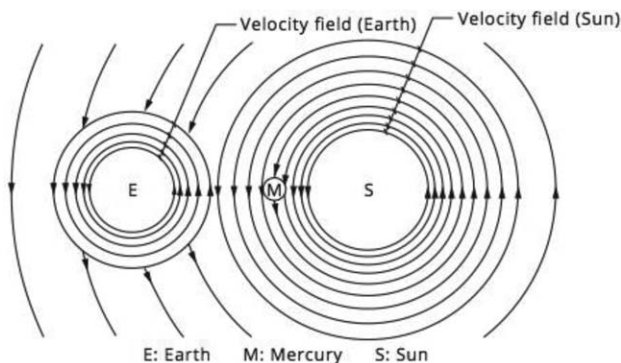

FIG. 16. Solar space vortex. S: Sun; M: Mercury; E: Earth.

Sun and the Earth are shown as circular (Fig. 16) streamlines. The planetary plane has been taken disk-shaped, with its thickness equal to the diameter of the Sun. Consider an elemental area dA on the rotating surface of the Sun, such that

$$dA = 2\pi R_s \sin \theta R_s d\theta. \tag{47}$$

The period of axial rotation of the Sun varies from 26 days at the equator to 37 days at the poles. If the average angular velocity of rotation be ω_s , then the tangential velocity at the elemental surface will be

$$V_s = \omega_s R_s \sin \theta, \tag{48}$$

where V_s is also the velocity field of space in the immediate vicinity of the surface, and tangential to the elemental area dA .

Due to V_s acting on each point of dA , there will be an *inward* acceleration as such that

$$a_s = V_s^2 / R_s \sin \theta. \tag{49}$$

The nuclei of atoms constituting the Sun have independent electrons in their structure. Similar to the electron, which, due to central void, has inward acceleration field on its interface, the Sun and the planets too have inward acceleration fields on their surfaces. The product $dA a_s$ is a field flux ϕ_s

$d\phi_s = (2\pi R_s^2 \sin \theta d\theta) [(\omega_s R_s \sin \theta)^2 / R_s \sin \theta]$ where ϕ_s is defined as “space acceleration flux.” Integrating, varying θ from 0 to π

$$\phi_s = 2\pi R_s (\omega R_s)^2 \int \sin^2 \theta d\theta = \pi^2 R_s (\omega R_s)^2. \tag{50}$$

From Eq. (49) for $\theta = \pi/2$, V_s has a maximum value on the Sun’s surface in the equatorial (planetary) plane of the Sun: $V_{sm} = \omega R_s$. Substituting this relationship in Eq. (50)

$$\phi_s = \pi^2 (V_{sm})^2 R_s. \tag{51}$$

Due to zero-viscosity and continuity of the medium of space, the acceleration flux remains constant at every spherical space-surface, concentric with the Sun’s center. Figure 15 shows a spherical space surface S .

From Eq. (50),

$$(V_{sm})^2 R_s = \phi_s / \pi^2 = \text{constant, Or, } V_{sm} \propto 1/\sqrt{R_s}. \tag{52}$$

From the above, it is seen that the tangential velocity V_{sm} at the Sun’s surface and also of the space-point in contact with the Sun’s surface (stated before), fall inversely as the square root of the distance from the Sun’s center (due to above mentioned constancy of the acceleration flux). If, in the solar vortex, V_t is the tangential velocity-field on the circumferential points of a circle of radius r in the planetary plane (Sun’s equatorial plane) concentric with the Sun, then, from

$$V_t \propto 1/\sqrt{r} = k/\sqrt{r}, \tag{53}$$

where k is a constant pertaining to the solar space-vortex. The velocity fields of the solar space vortex carry the planets in their orbits. Therefore, from Eq. (53) it follows that the

orbital speed of the planets should be inversely proportional to the square root of the distance from the Sun's center, which, in fact, is as per Kepler's third law

$$T^2 \propto r^3, \quad (54)$$

where T is the period of any of the planets of the solar system, and r is its distance from the Sun's center.

Substituting in the above equation, $T = 2\pi r / V$, where V is the orbital velocity of the planet. From Eq. (54)

$$(2\pi r/V)^2 \propto r^3$$

$$\text{Or } V \propto 1/\sqrt{r}. \quad (55)$$

A theoretical proof to the third law of Kepler (54), which is supported by astronomical measurements, is provided by deriving this law with the concept of "space acceleration field" acting on the surface of the Sun in the solar space vortex. The flux of the acceleration field (Fig. 15) varies spherically covering all the planets (only partial view of the planetary plane is shown in Fig. 15 to derive the Kepler Johannes' law). The planetary plane is all around the Sun's equatorial diameter.

B. Free fall acceleration on the sun's surface

Let us consider the innermost planet of the solar system, Mercury, which has an orbital speed of 47.9 km/s, and the mean distance from the Sun's center: 57.9×10^6 km. With substitution in Eq. (53)

$$\begin{aligned} k &= 47.9 \times 10^3 \text{ m/s} (57.9 \times 10^9 \text{ m})^{1/2} \\ &= 11.52 \times 10^9 \text{ m}^{3/2}/\text{s}. \end{aligned} \quad (56)$$

The maximum tangential velocity of space (V_{sm}) on the periphery of the Sun in the planetary plane is now found by substituting the value of k and the mean-radius of the Sun

$$\begin{aligned} V_{sm} &= (11.52 \times 10^9 \text{ m}^{3/2}/\text{s}) / (6.96 \times 10^8 \text{ m})^{1/2} \\ &= 4.367 \times 10^5 \text{ m/s}. \end{aligned} \quad (57)$$

This tangential velocity-field will create on the surface of the Sun in the planetary plane an inward space acceleration field of maximum value

$$\begin{aligned} a_{fm} &= (4.367 \times 10^5 \text{ m/s})^2 / 6.96 \times 10^8 \text{ m} \\ &= 274 \text{ m/s}^2. \end{aligned} \quad (58)$$

As per classical mechanics, the surface gravity of the Sun is also 274 m/s^2 , which happens to be exactly the same as the space acceleration field derived above.

C. Genesis of the solar wind

As per recorded data on the solar wind close to the surface of the Sun, the wind velocity varied from a minimum of about 380 km/s to the maximum of about 500 km/s, giving

an average of 440 km/s (<http://soho.nascom.nasa.gov/>; 48 h of solar wind data on 10 July 2002). While the Sun rotates axially at a peripheral speed of about 2 km/s at the equator in the plane at right angles to its axis, the reason for so high a wind velocity is briefly explained below. From Eq. (58), maximum velocity field at the solar surface is 436.7 km/s. This shows that in the near hood of the Sun's surface, its gaseous matter will be subjected to a maximum average velocity of 436.7 km/s, due to fluid-space circulation around the Sun in the solar space vortex. The above computed value is so very close to the recorded data (440 km/s) mentioned above.

D. Creation of matter at sun's center

From solar space vortex, the constant k was determined Eq. (56) as: $k = 11.52 \times 10^{12} \text{ cm}^{3/2}/\text{s}$; and the maximum tangential velocity of space circulation in the equatorial plane was determined as: $V_{sm} = 4.367 \times 10^7 \text{ cm/s}$ Eq. (57). Consider the case when the Sun had no matter, and the solar space-vortex extended all the way up to its center. From the solar vortex equation (53)

$$\sqrt{r} = k/v_t. \quad (59)$$

For creation of matter the space circulation speed should reach c . Substituting the values of k given above, and $v_t = 3 \times 10^{10} \text{ cm/s}$ in Eq. (59)

$$\sqrt{r} = (11.52 \times 10^{12} \text{ cm}^{3/2}/\text{s}) / 3 \times 10^{10} \text{ cm/s}.$$

or,

$$r = 1.475 \times 10^5 \text{ cm}. \quad (60)$$

In the central zone of the Sun, within a diameter of about 2.95 km at the axis of rotation, the medium of space undergoes break down, and matter is created starting from the electrons/positron continuously. It appears that the created matter accumulated within the Sun over a period of time leads to intermittent solar bursts that should account for the observed solar flares.

The stars, formed initially from galactic matter, create their own matter.

E. Creation of matter at centers of large planets

Part of the gaseous matter at the solar surface is constantly whirled in space by the velocity field of 436.7 km/s tangential to the equatorial surface against the inward acceleration field (free fall acceleration) on the Sun, as given in Eq. (58). This matter is also interacted with by the velocity field in the solar vortex as it travels in the planetary plane away from the Sun. The planets' formation can be supposed to be from the above solar matter.

F. Free fall acceleration on the earth's surface

Refer to Fig. 16 and Fig. 17.

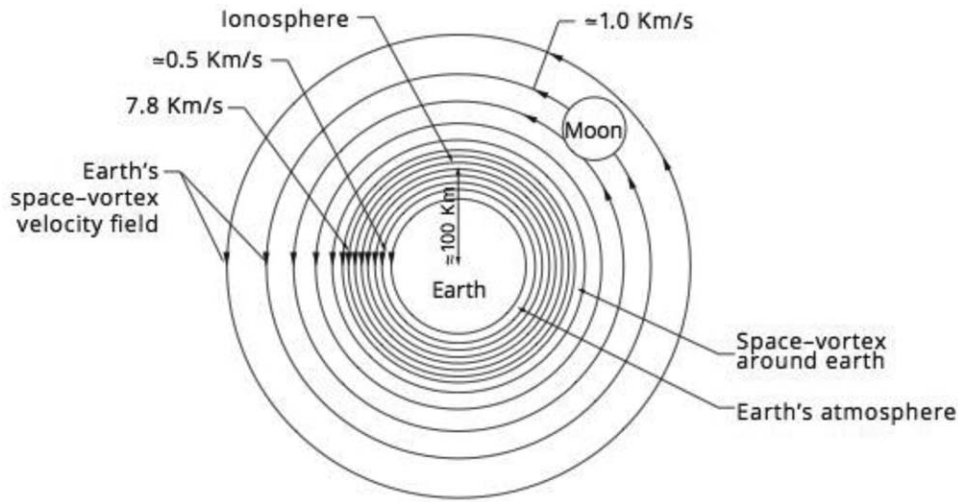

FIG. 17. Earth's space-vortex.

G. Earth's gravity field

Refer to Fig. 17. The Earth is enclosed within a space vortex that imparts axial rotation to it and carries the Moon; the Moon cannot be supposed to have space vortex around it, since it does not possess axial rotation. The Earth along with the Moon is carried by the solar space vortex in an elliptical (assumed circular for simplicity) orbit Fig. 16. The velocity field in the Earth vortex carries the Moon around the Earth with an orbital speed of 1017 m/s (derived from the period of 27.3 days; radius of the orbit: 3.82×10^5 km)

$$V_m \propto 1/\sqrt{r} = k_e/\sqrt{r}, \tag{61}$$

where V_m is the orbital velocity of the Moon; r is its distance from the Earth center; and k_e is a constant pertaining to the Earth's space-vortex. Substituting the values of V_m and the radial distance of the Moon's orbit, given earlier,

$$\begin{aligned} k_e &= (1017 \text{ m/s}) \times (3.82 \times 10^8 \text{ m})^{1/2} \\ &= 1.987 \times 10^7 \text{ m}^{3/2}/\text{s}. \end{aligned} \tag{62}$$

Substituting the values of k_e and r in Eq. (61), which is the known radius of the Earth, the maximum tangential velocity of space in the equatorial plane and in close vicinity of the Earth surface (top of the atmosphere), is determined as

$$\begin{aligned} V_t &= (1.987 \times 10^7 \text{ cm}^{3/2}/\text{s}) / (6.37 \times 10^6 \text{ m})^{1/2} \\ &= 7.8 \times 10^3 \text{ m/s}. \end{aligned} \tag{63}$$

There exists a vacuum space-circulation at 7.8 km/s around the Earth's surface in its equatorial plane that imparts axial rotation to it, and also develops an inward acceleration field which is

$$\begin{aligned} a_e &= V_t^2/R_e = (7.8 \text{ km/s})^2/6370 \text{ km} \\ &= 9.55 \text{ m/s}^2, \end{aligned} \tag{64}$$

where R_e is the radius of the Earth. The inward acceleration field, derived above, is seen to be so close to the presently

accepted surface gravity of the Earth: 9.81 m/s^2 , obtained from experimental measurements.

The proof on the real existence of space vortices around the Earth and the Sun lies in the above derivations of free-fall accelerations on the surfaces of these cosmic bodies.

H. Free fall acceleration on the core of galaxy

The solar system exists at a distance of about 2.62×10^{22} cm from the center of the galaxy, revolving around it at the speed of 220 km/s (2.20×10^7 cm/s) (Fig. 18). Assuming that similar to the velocity field distribution in the solar vortex, in the galactic vortex, too, the space-circulation (in the diametrical plane at right angles to the axis) falls inversely as the square root of the distance from the center of the galaxy

$$v = k_g/\sqrt{r}, \tag{65}$$

where k_g is a constant, and r is the distance from the galactic center.

Substituting the values of v and r as given above we get

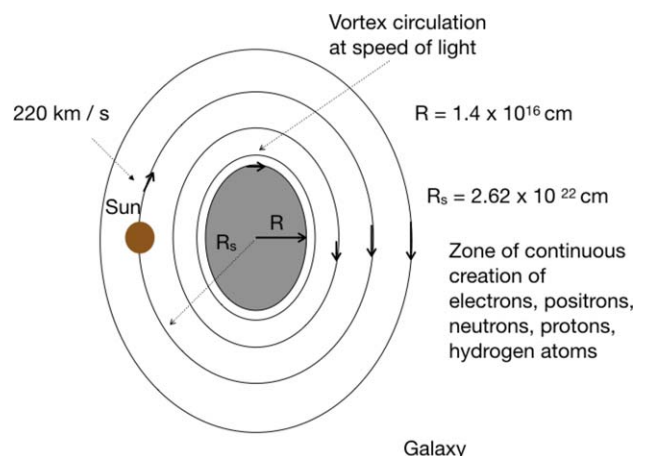

FIG. 18. (Color online) Galaxy.

$$k_g = v\sqrt{r} = (220 \times 10^5 \text{ cm/s})(2.62 \times 10^{22} \text{ cm})^{1/2} \\ = 3.56 \times 10^{18} \text{ cm}^{3/2}/\text{s}. \quad (66)$$

From Eqs. (65) and (66), the distance R_g at which the space circulation in the galactic vortex reaches the speed of light is

$$R_g = \left[\left(3.56 \times 10^{18} \text{ cm}^{3/2}/\text{s} \right) / (3 \times 10^{10} \text{ cm/s}) \right]^2 \\ = 1.408 \times 10^{16} \text{ cm}, \quad (67)$$

which is about 203 000 times more than the solar radius.

Free fall acceleration at the surface of the galactic core $= c^2/R_g = (3 \times 10^{10})^2 / (1.408 \times 10^{16} \text{ cm}) = 6.392 \times 10^4 \text{ cm/s}^2 = 639.2 \text{ m/s}^2$, which is 2.33 times the free fall acceleration on the Sun's surface.

Within the central zone of the galaxy, a nearly spherical volume of radius 203 000 times the Sun's radius is the region of continuous creation of matter starting from the electrons/positrons. With violent motion of these particles at the speed of light, the electrons will magnetically attract and electrically repel, thus coming to close ranges, and creating neutrons, protons and hydrogen atoms, projected out from the galaxy's central zone, as beams of hydrogen at speeds approaching light speed. The electrons with opposite spins (positrons) will have chance-encounters with electrons, leading to annihilation, and thus producing gamma radiation. Therefore, it follows, that all those galactic centers that are pushing out jets of hydrogen, and are sources of intense gamma radiation, are located in the active region of the universe, continuously creating matter, and thereby increasing the mass of the galaxies, and dispersing matter in the cosmic space for the formation of stars. The creation of matter should be a distinct possibility at the center of stars as well, as seen in case of the Sun.

The mass of matter within the creation zone of the galaxy is found as follows.

The volume of the creation zone, $V_g = (4\pi/3) R_g^3$; and mass of the galaxy, $M_g = V_g c$, since the entire volume of space in the creation zone circulates at c . Substituting the value of R_g from Eq. (67), $M_g = (4\pi/3) (1.408 \times 10^{16} \text{ cm})^3 (3 \times 10^{10} \text{ cm/s}) = 3.5 \times 10^{59} \text{ cm}^4/\text{s}$. Converting cm^4/s into gram from Eq. (10), $M_g = (3.5 \times 10^{59}) \text{ g}/8.6 \times 10^6 = 3.49 \times 10^{52} \text{ g}$.

I. Solar mass

The following computation of the solar mass is independent of the surface gravity of the Sun and also the gravitational constant. From Eq. (6), mass of the electron is proportional to its maximum velocity field c , and the volume of its single void. Similarly, for the Sun, we can write

$$M_s = V \times V_s = (V \times c)V_s/c, \quad (68)$$

where V is the volume of the sun; V_s : maximum velocity field in the Sun's vortex; M_s : mass of the Sun.

Since the volume of the Sun is not a total void, and is composed of multiple electronic voids in the nuclei and

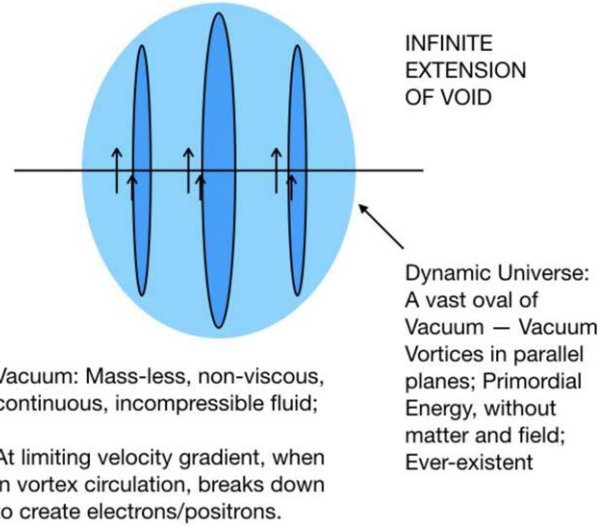

FIG. 19. (Color online) Infinite extension of void.

atoms constituting the Sun, V_s is less than c and, therefore, M_s is reduced by a factor V_s/c as shown in the above relation. Substituting the value of V and V_s in the above equation

$$M_s = (4\pi/3)R_s^3V_s \\ = (4\pi/3)(6.96 \times 10^{10})^3(4.367 \times 10^7 \text{ cm/s}) \\ = 6.16 \times 10^{40} \text{ cm}^4/\text{s} = 6.16 \times 10^{40} (\text{g}/8.6 \times 10^6) \\ = 7.16 \times 10^{33} \text{ g},$$

where from Eq. (10), $\text{gram} = 8.6 \times 10^6 \text{ cm}^4/\text{s}$.

Presently, accepted mass of the Sun is: $M_s = 1.99 \times 10^{33} \text{ g}$ which is reasonably¹⁾ close.

XIV. UNIVERSE

The Universe is a sphere of vacuum space existent in an infinite void of nothingness (Fig. 19). It turns into an ellipsoid due to the rotation on one of its diametrical axis. Due to vacuum vortex rotation at c at the axis of rotation in diametrical plane, and other parallel planes, cosmic matter is created; the process being the transfer of energy from the vacuum space to matter, till the vortex motion of the vacuum space is depleted, and the matter gets annihilated in each unit of electron and positron. The annihilation age restores back the original vacuum energy, and the creation age starts. It is a cyclical universe, from vacuum energy to matter, and back to vacuum energy.

A. Conclusion

The seat of cosmic energy in the universe is the absolute dynamic vacuum substratum. This energy is used to create all matter, including the cosmic bodies, and causes their motion. The creation and annihilation of matter is cyclic, in which the dynamic vacuum space transfers its energy to

¹⁾The Essential Tension—The Function of Measurement in Modern Physical Science, Thomas S. Kuhn: "In the theoretical study of Stellar magnitudes agreement to a multiplicative factor of ten is often taken to be reasonable."

matter, and retrieves it when matter is annihilated. The cycle is eternal.

Planck constant is the angular momentum of the electron. In equation $E = hf$, $h = E/f$, that is energy in one shell of light. In thermal radiation, energy in one shell of light is close to h . An oscillating electron too produces energy in one shell of light close to h .

In thermal radiation, atoms have no energy storing system. Therefore, to store the energy produced by f nos. of shells (hf) to make a packet of energy (photon) is not physically possible. The electron cannot emit or absorb any particle/energy. Atoms cannot produce light beyond a limiting frequency, when their oscillations cease due to reaction from the vacuum space.

¹I. Newton's *The Principia*, edited by A. Koyre and I. B. Cohen (Cambridge University Press, London, 1972).

²E. T. Whittaker, *A History of The Theories of Aether and Electricity* (Thomas Nelson, London, 1953).

³P. Tewari, *Universal Principles of Space and Matter—A Call for Conceptual Reorientation* (Crest Publishing House, New Delhi, 2002).

⁴G. Yankovsky, *Philosophical Problems of Elementary Particles Physics* (Progress Publishers, Moscow, 1968).

⁵P. Tewari, *Discovering Universal Reality—The Structural Relationship Between Space and Matter* (Editions India, Cochin, India, 2008).

⁶P. Tewari, *Beyond Matter—A Comprehensive Theory of The Material Universe* (Edition Freie Energie, Wiesbaden, Germany, 1995).

⁷P. Tewari, paper presented at the German Association of Gravity Field Energy. International Conference on Gravity Field Energy, Hannover, Germany (1987).

⁸P. Tewari, *Foundations of Mathematics and Physics: Proceedings of the Conference, Perugia, Italy, 1989* (B. Wesley, Blumberg, Germany, 1990).

⁹P. Tewari, *Proceedings of the International Symposium on New Energy, USA* (Rocky Mountain Research Institute, Centennial, CO, 1994), Vol. 1, p. 291.

¹⁰P. Tewari, paper presented at the Congresso Interzionale, Perugia, Italy (1996).

¹¹P. Tewari, paper presented at Galileo Back in Italy International Conference, Bologna, Italy (1999).

¹²P. Tewari, paper presented at the International Conference (Psychotronics), Japan (1996).

¹³P. Tewari, "Space is the absolute reality," in *Proceedings of ICSTA* (International Publishers East-West, Graz, Austria, 1982).

¹⁴P. Tewari, *J. New Energy* 3, 143 (1998); 3, 102 (1999).